

SUBMERSIBLE MOTORS

50-60 HZ CATALOGUE

AN ISO 9001:2015 COMPANY, C E 



PARTNERING, PROPELLING, PROSPERING

GLOBAL PRESENCE

La-Gajjar Machinerics was born out of a deep concern for water. Guiding us to transcend boundaries and reach out to some of the most unaccessed lands.

Today, as partners with more than 38 nations of the globe, our unmatched water solutions are successfully transforming challenge to opportunity and co-creating wealth, abundance and growth.



COMPREHENSIVE, CUSTOMIZED, COMPETITIVE

APPLICATION

Our wide range of products offer comprehensive, viable, sustainable and tested solutions for diverse customer needs across different locations.

DOMESTIC WATER SOLUTIONS

A range of submersible pump sets, jet pumps, multistage centrifugal pumps and compact systems for easy domestic applications.

AGRICULTURAL WATER SOLUTIONS

Submersible and dry installed pumps for easy groundwater supply and groundwater lowering.

INDUSTRIAL WATER SOLUTIONS

Supreme mechanisms catering to industrial needs like transfer of water, cooling lubricants and other liquids in industrial processes.

WASTE WATER MANAGEMENT

Varuna offers a broad range of equipment designed specifically for wastewater handling and treatment. The sustainability of a sewage treatment plant requires that the solution is durable, ensuring cost effective and trouble-free operation.

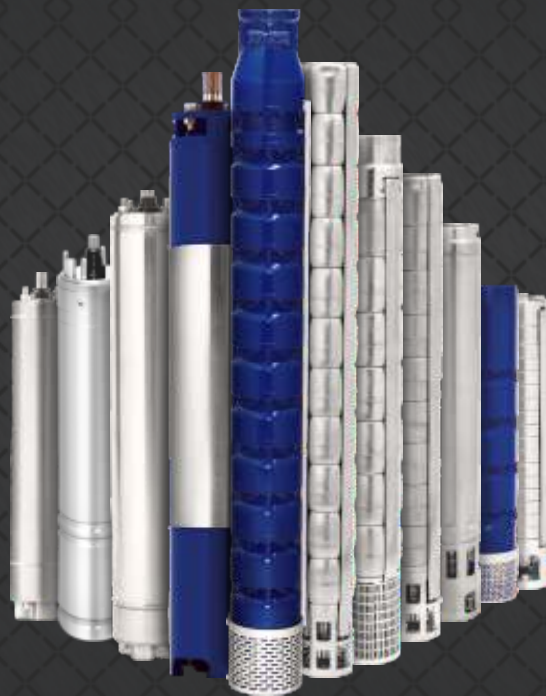

LEGACY

Across distances and time, Water – Earth's most precious resource continues to remain its biggest challenge. Depleting water resources today compel us to look beyond traditional water solutions to build ways to optimise our lifeline. La-Gajjar Machineries founded in 1935 by Shri Laljibhai Gajjar came to life when the world was waking up to its water woes.

By introducing water solutions under the brand name Varuna, it not only rose to the unmet needs of water, but also raised opportunities for people and global communities to reap in abundance and growth.

Today, as one amongst the largest manufacturers of submersible pumps and motors in India, exporting to more than 50 countries across the globe, we have with us the unique experience and expertise of nearly 8 decades.

Carrying the legacy forward, we stand committed to raise value and reach out to customers across diverse needs or geographic locations. We stand together as responsible partners to celebrate growth and prosperity for our people and our world.



INDEX

SUBMERSIBLE REWINDABLE MOTORS	PAGE NO.
3" OIL LUBRICATED MOTORS	1 - 5
3" WATER LUBRICATED MOTORS	6 - 10
4" OIL LUBRICATED MOTORS	11 - 18
4" WATER LUBRICATED MOTORS	19 - 26
5" WATER LUBRICATED MOTORS	27 - 30
6" WATER LUBRICATED MOTORS	31 - 44
8" WATER LUBRICATED MOTORS	45 - 49
9" WATER LUBRICATED MOTORS	50 - 53
10" WATER LUBRICATED MOTORS	54 - 57

Submersible Motor

3" OIL LUBRICATED REWINDABLE MOTOR

TECHNICAL SPECIFICATIONS:

- 3" Oil Lubricated Motors are rewindable.
- Winding wires are Enamelled dual coated.
- Insulation class : B.
- Degree of protection : IP58.
- Max oil temperature : 35°C.
- Start per hour : 30 times (Max.).
- Allowable voltage variation : +6% - 10%.
- Motor shaft of Stainless Steel.
- Stator shell of Stainless Steel.
- Max depth immersion : 100M.
- Mounting : Vertical / Horizontal.
- Upper / Lower bracket in Cast Iron with Epoxy Point
- Single Phase Motors are Capacitor start and run.
- Motor Cable length : 3 Meter (3 Core / earth wire separate on demand).
- Coolant : Die electric non - toxic.

VERSIONS:

Single Phase : 0.37 kW to 1.10 kW, 220-230 Volt / 50 Hz.

Single Phase : 0.37 kW to 1.10 kW, 230 Volt / 60 Hz.

Motors with other Voltage and frequency ratings are available on specific demand.

3" O/L REWINDABLE MOTOR

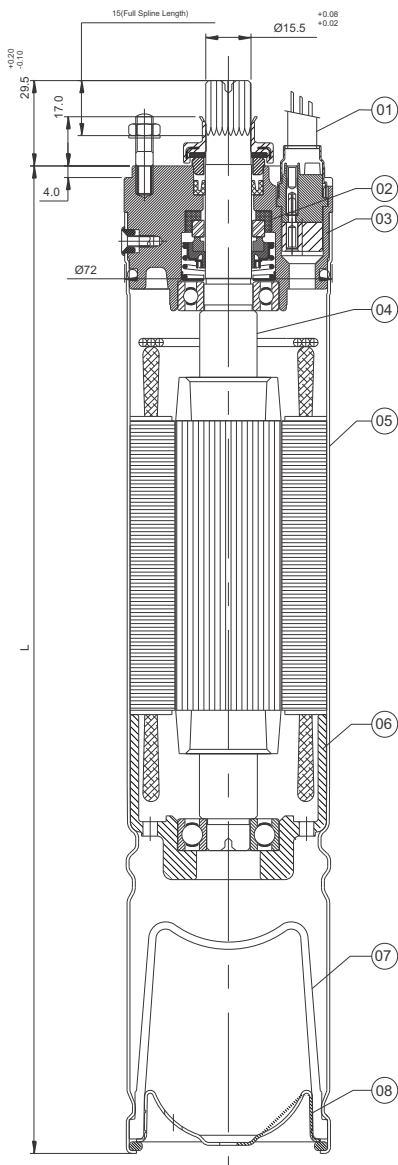
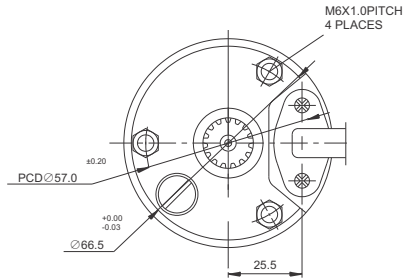

No.	PARTS NAME	MATERIAL
01	CABLE 3 CORE/4 CORE	P.V.C
02	MECH. SEAL	CERAMIC/CARBON
03	UPPER HOUSING	CAST IRON (FG 200)
04	ROTOR SHAFT	S.S.420
05	MOTOR SHELL	S.S.304
06	LOWER HOUSING	CAST IRON (FG 200)
07	PRESSURE CUP	HBR
08	MOTOR BASE PLATE	S.S.304
09	ALL HARDWARE	S.S.304

P _N		S.P. L [mm]	MOTOR WEIGHT [kg]	MOTOR WEIGHT (incl.pkg)[kg]
[kW]	[H.P.]			
0.37	0.50	338	7.50	8.50
0.55	0.75	363	8.00	9.00
0.75	1.00	388	8.50	9.50
0.94	1.25	413	9.50	10.5

P _N		T,P L [mm]	MOTOR WEIGHT [kg]	MOTOR WEIGHT (incl.pkg)[kg]
[kW]	[H.P.]			
1.10	1.5	438	10.00	11.00

Submersible Motor

Technical Data of 3" Motors Single Phase (220-230 Volt / 50 Hz) CSR

PN		Thrust Load [N]	UN [V]	nN [min-1]	IN [A]	IA [A]	ι (Eff.) [%] at % load			cos κ (PF) at % load			TN [Nm]	TA [Nm]	Capacitor Running vF (Uc=450V)
[H.P.]	[kW]						50	75	100	50	75	100			
0.50	0.37	1500	220	2690	5.00	6.30	33	34	35	0.94	0.96	0.97	1.30	0.99	30
			230	2700	4.80	6.60	31	32	33	0.92	0.95	0.97	1.30	1.01	
0.75	0.55	1500	220	2690	5.40	8.90	34	36	39	0.92	0.95	0.96	1.95	1.35	30
			230	2700	5.20	9.35	32	34	37	0.91	0.93	0.94	1.95	1.48	
1.00	0.75	1500	220	2740	6.20	10.70	44	48	50	0.92	0.96	0.97	2.55	2.07	30
			230	2750	6.00	11.20	42	46	48	0.91	0.95	0.96	2.55	2.27	
1.50	1.10	1500	220	2740	6.80	12.40	50	51	55	0.90	0.92	0.95	3.83	2.91	30
			230	2750	6.60	13.00	48	49	53	0.88	0.90	0.93	3.83	3.22	

Technical Data of 3" Motors Single Phase (220-230 Volt / 50 Hz) CSCR

PN		Thrust Load [N]	UN [V]	nN [min-1]	IN [A]	IA [A]	ι (Eff.) [%] at % load			cos κ (PF) at % load			TN [Nm]	TA [Nm]	Capacitor Running vF (Uc=450V)	Capacitor Starting vF (Uc=270V)
[H.P.]	[kW]						50	75	100	50	75	100				
0.50	0.37	1500	220	2690	5.00	6.30	33	34	35	0.94	0.96	0.97	1.30	2.17	30	100-120
			230	2700	4.80	6.60	31	32	33	0.92	0.95	0.97	1.30	2.17		
0.75	0.55	1500	220	2690	5.40	8.90	34	36	39	0.92	0.95	0.96	1.95	2.92	30	100-120
			230	2700	5.20	9.35	32	34	37	0.91	0.93	0.94	1.95	2.92		
1.00	0.75	1500	220	2740	6.20	10.70	44	48	50	0.92	0.96	0.97	2.55	4.18	30	100-120
			230	2750	6.00	11.20	42	46	48	0.91	0.95	0.96	2.55	4.18		
1.50	1.10	1500	220	2740	6.80	12.40	50	51	55	0.90	0.92	0.95	3.83	6.21	36	100-120
			230	2750	6.60	13.00	48	49	53	0.88	0.90	0.93	3.83	6.21		

- PN - Rated Output
- F[N] - Axial Thrust Load
- UN - Rated Voltage
- nN - RPM
- IN - Full Load Current
- IA - Starting Current
- ι - Motor Efficiency
- cosκ - Power Factor
- TN - Full Load Torque
- TA - Starting Torque

Technical Data of 3" Motors Single Phase / 60 Hz (CSR)

PN		Thrust Load [N]	UN [V]	nN [min-1]	IN [A]	IA [A]	ι (Eff.) [%] at % load			cos κ (PF) at % load			TN [Nm]	TA [Nm]	Capacitor Running vF (Uc=450V)
[H.P.]	[kW]						50	75	100	50	75	100			
0.5	0.37	1500	230	3430	4.6	12.2	38	40	42	0.80	0.82	0.84	1.02	0.84	20
0.75	0.55	1500	230	3430	6.3	17.3	45	47	49	0.86	0.88	0.91	1.54	1.26	30
1.0	0.75	1500	230	3440	8.7	23	48	50	51	0.88	0.90	0.92	2.04	1.82	30
1.5	1.1	1500	230	3440	12	34	49	51	53	0.87	0.88	0.90	3.06	2.6	36

- PN - Rated Output
- F[N] - Axial Thrust Load
- UN - Rated Voltage
- nN - RPM
- IN - Full Load Current
- IA - Starting Current
- ι - Motor Efficiency
- cosκ - Power Factor
- TN - Full Load Torque
- TA - Starting Torque

Technical Data of 3" Motors Single Phase / 60 Hz (CSCR)

PN		Thrust Load [N]	UN [V]	nN [min-1]	IN [A]	IA [A]	ι (Eff.) [%] at % load			cos κ (PF) at % load			TN [Nm]	TA [Nm]	Capacitor Running vF (Uc=450V)	Capacitor Starting vF (Uc=270V)
[H.P.]	[kW]						50	75	100	50	75	100				
0.5	0.37	1500	230	3430	4.6	12.2	38	40	42	0.80	0.82	0.84	1.02	1.70	20	100-120
0.75	0.55	1500	230	3430	6.3	17.3	45	47	49	0.86	0.88	0.91	1.54	2.31	30	100-120
1.0	0.75	1500	230	3440	8.7	23	48	50	51	0.88	0.90	0.92	2.04	3.35	30	100-120
1.5	1.1	1500	230	3440	12	34	49	51	53	0.87	0.88	0.90	3.06	4.96	36	100-120

- PN - Rated Output
- F[N] - Axial Thrust Load
- UN - Rated Voltage
- nN - RPM
- IN - Full Load Current
- IA - Starting Current
- ι - Motor Efficiency
- cosκ - Power Factor
- TN - Full Load Torque
- TA - Starting Torque

Submersible Motor

Exploded Drawing of 3" O/L Motors

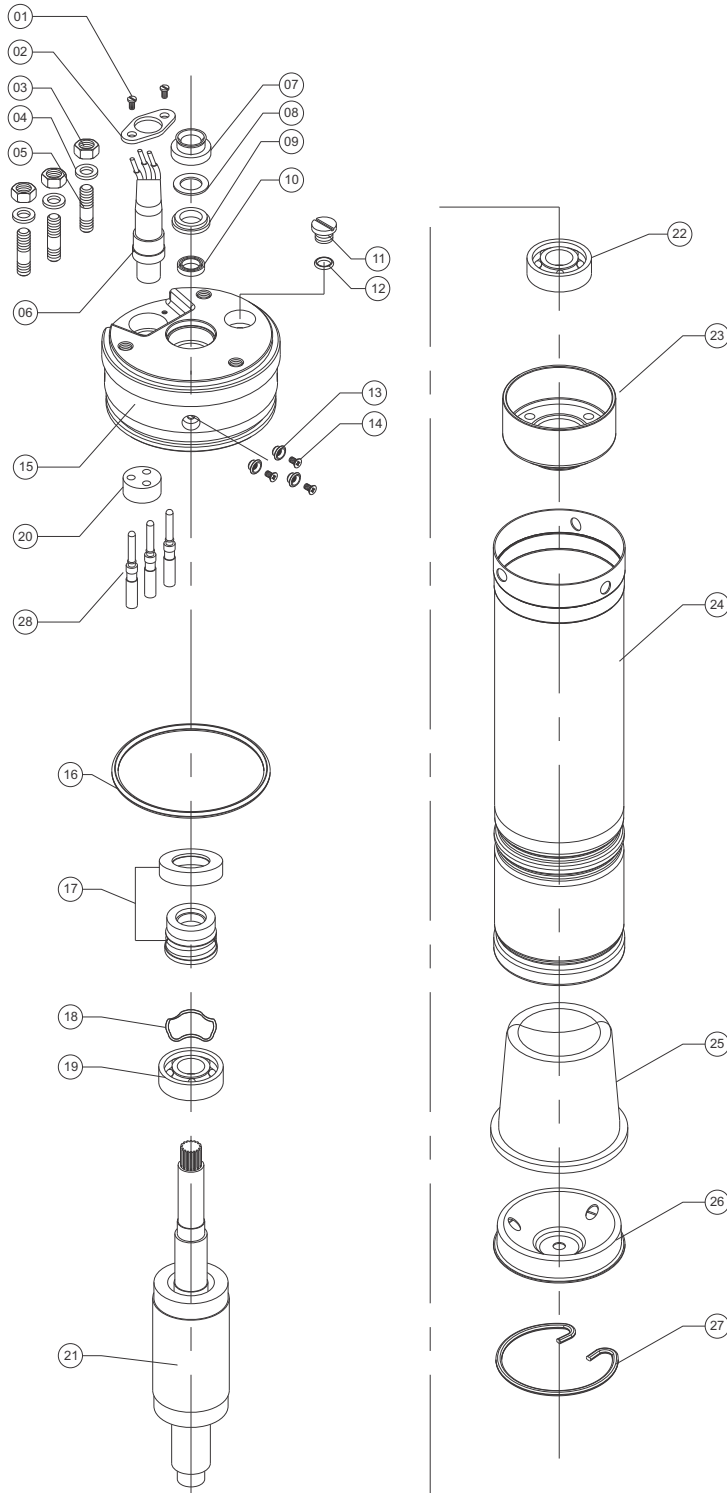

No.	Parts Name
1	CABLE CLIP SCREW
2	CABLE CLIP
3	HEX NUT
4	SPRING WASHER
5	UPPER STUD
6	CABLE SET
7	SAND GUARD
8	TEFLON WASHER
9	UPPER COLLAR
10	OIL SEAL
11	DRAIN PLUG
12	DRAIN PLUG 'O' RING
13	SCREW COLLAR
14	SCREW (FOUR WAY)
15	UPPER HOUSING
16	O' RING (UPPER HOUSING)
17	MECH. SEAL
18	WAVE WASHER
19	BALL BEARING (UPPER SIDE)
20	SMALL GROMMET
21	ROTOR FINISH
22	BALL BEARING (LOWER SIDE)
23	LOWER HOUSING
24	STATOR BODY
25	PRESSURE CUP
26	MOTOR BASE PLATE
27	CIR CLIP
28	MALE PIN
29	FEMALE PIN

3" WATER LUBRICATED REWINDABLE MOTORS

TECHNICAL SPECIFICATIONS:

- 3" Water lubricated Motors are rewindable.
- Winding wire: Polywrapped.
- Degree of protection : IP68.
- Max water temperature : 35° C.
- Start per hour: 30 times (Max.).
- Allowable voltage variation: +6% -10%.
- Motor shaft of Stainless Steel.
- Stator shell of Stainless Steel.
- Max depth immersion : 100 M.
- Mounting : vertical / horizontal.
- Upper / Lower bracket in Cast Iron with Epoxy Paint.
- Single Phase Motors are Capacitor start and run.
- Motor Cable length : 3 Meter (3 Core / earth wire separate on demand).
- Coolant : Clear Water.

VERSIONS:

Single Phase : 0.37 kW to 1.10 kW , 220 - 230Volt / 50 Hz.

Single Phase : 0.37 kW to 1.10 kW, 230 Volt / 60 Hz.

Motors with other Voltage and frequency ratings are available on specific demand.

Submersible Motor

3" W/L REWINDABLE MOTOR

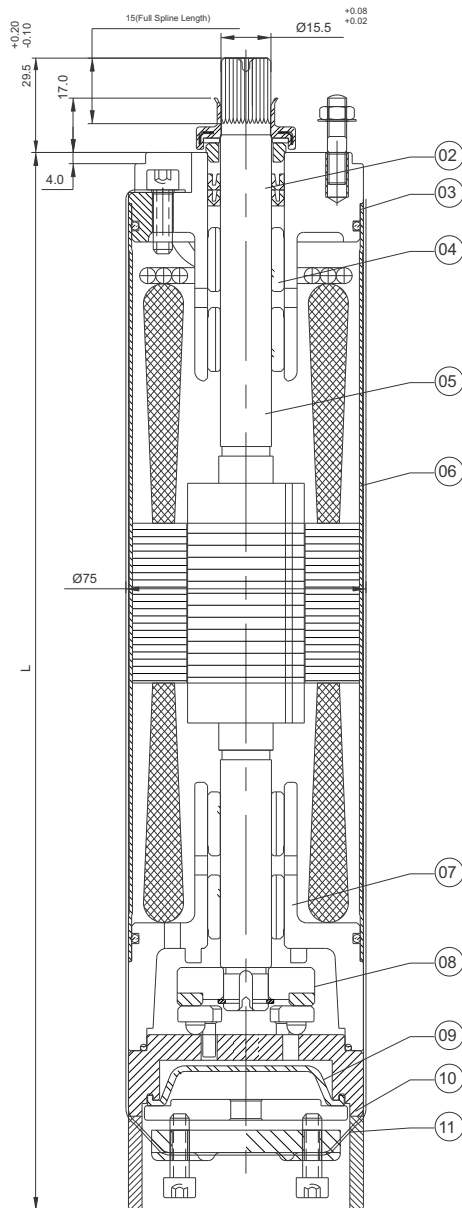
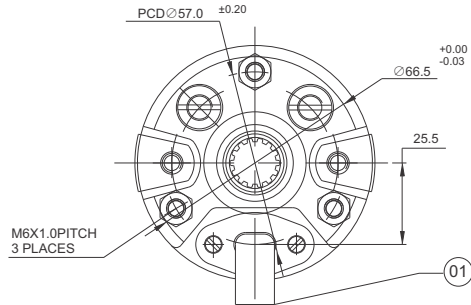

NO.	PARTS NAME	MATERIAL
01	CABLE 3 CORE	P.V.C
02	OIL SEAL	N.B.R
03	UPPER HOUSING	CAST IRON (F.G 200)
04	BEARING BUSH	L.T.B-4(2%Ni)
05	ROTOR SHAFT	S.S.420
06	MOTOR SHELL	S.S.304
07	LOWER HOUSING	CAST IRON (F.G 200)
08	THRUST BEARING	CARBON / S.S.420
09	PRESSURE CUP	HBR
10	MOTOR BASE	CAST IRON (F.G 200)
11	CLAMPING STRIP	S.S.304
12	ALL HARDWARE	S.S.304

P _N		S.P. L [mm]	MOTOR WEIGHT [kg]	MOTOR WEIGHT (incl.pkg)[kg]
[kW]	[H.P.]			
0.37	0.50	391	8.50	9.50
0.55	0.75	406	9.50	10.5
0.75	1.00	421	11.0	12.0
1.10	1.50	496	12.0	13.0
1.10	1.50	481	11.5	12.5
1.50	2.00	531	13.5	14.5
1.50	2.00	511	13.0	14.0

Technical Data of 3" Motors Single Phase (220-230 Volt / 50 Hz) CSR

PN		Thrust Load [N]	UN [V]	nN [min-1]	IN [A]	IA [A]	ι (Eff.) [%] at % load			cos κ (PF) at % load			TN [Nm]	TA [Nm]	Capacitor Running vF (Uc=450V)
[H.P.]	[kW]						50	75	100	50	75	100			
0.50	0.37	1500	220	2870	4.20	8.00	34	35	36	0.89	0.92	0.93	1.20	0.91	50
			230	2880	4.70	8.40	33	34	35	0.88	0.90	0.92	1.20	1.00	
0.75	0.55	1500	220	2870	5.20	13.20	36	39	41	0.84	0.86	0.88	1.80	1.24	50
			230	2880	6.00	13.70	35	37	39	0.81	0.83	0.85	1.80	1.37	
1.00	0.75	1500	220	2850	7.00	16.10	48	49	51	0.75	0.77	0.78	2.46	1.99	72
			230	2860	8.50	16.80	46	47	50	0.73	0.74	0.75	2.46	2.19	
1.50	1.10	1500	220	2790	8.50	16.10	53	55	56	0.77	0.79	0.85	3.78	2.87	72
			230	2800	9.00	16.80	51	53	55	0.76	0.78	0.83	3.76	3.15	

Technical Data of 3" Motors Single Phase (220-230 Volt / 50 Hz) CSCR

PN		Thrust Load [N]	UN [V]	nN [min-1]	IN [A]	IA [A]	ι (Eff.) [%] at % load			cos κ (PF) at % load			TN [Nm]	TA [Nm]	Capacitor Running vF (Uc=450V)	Capacitor Starting vF (Uc=270V)
[H.P.]	[kW]						50	75	100	50	75	100				
0.50	0.37	1500	220	2870	4.20	8.00	34	35	36	0.89	0.92	0.93	1.20	2.00	50	100-120
			230	2880	4.70	8.40	33	34	35	0.88	0.90	0.92	1.20	2.00		
0.75	0.55	1500	220	2870	5.20	13.20	36	39	41	0.84	0.86	0.88	1.80	2.70	50	100-120
			230	2880	6.00	13.70	35	37	39	0.81	0.83	0.85	1.80	2.70		
1.00	0.75	1500	220	2850	7.00	16.10	48	49	51	0.75	0.77	0.78	2.46	4.00	72	100-120
			230	2860	8.50	16.80	46	47	50	0.73	0.74	0.75	2.46	4.00		
1.50	1.10	1500	220	2790	8.50	16.10	53	55	56	0.77	0.79	0.85	3.78	6.00	72	100-120
			230	2800	9.00	16.80	51	53	55	0.76	0.78	0.83	3.76	6.00		

- PN - Rated Output
- F[N] - Axial Thrust Load
- UN - Rated Voltage
- nN - RPM
- IN - Full Load Current
- IA - Starting Current
- ι - Motor Efficiency
- cosκ - Power Factor
- TN - Full Load Torque
- TA - Starting Torque

Submersible Motor

Technical Data of 3" Motors Single Phase / 60 Hz (CSR)

PN		Thrust Load [N]	UN [V]	nN [min-1]	IN [A]	IA [A]	ι (Eff.) [%] at % load			cos κ (PF) at % load			TN [Nm]	TA [Nm]	Capacitor Running vF (Uc=450V)
[H.P.]	[kW]						50	75	100	50	75	100			
0.5	0.37	1500	230	3440	5	13	38	43	44	0.74	0.76	0.78	1.02	0.85	36
0.75	0.55	1500	230	3440	7	18.5	48	49	50	0.74	0.78	0.80	1.53	1.16	36
1.0	0.75	1500	230	3450	9.5	24	48	50	52	0.75	0.79	0.81	2.04	1.79	61
1.5	1.1	1500	230	3450	14	50	50	52	54	0.75	0.77	0.80	3.06	2.57	61

- PN - Rated Output
- F[N] - Axial Thrust Load
- UN - Rated Voltage
- nN - RPM
- IN - Full Load Current
- IA - Starting Current
- ι - Motor Efficiency
- cosκ - Power Factor
- TN - Full Load Torque
- TA - Starting Torque

Technical Data of 3" Motors Single Phase / 60 Hz (CSCR)

PN		Thrust Load [N]	UN [V]	nN [min-1]	IN [A]	IA [A]	ι (Eff.) [%] at % load			cos κ (PF) at % load			TN [Nm]	TA [Nm]	Capacitor Running vF (Uc=450V)	Capacitor Starting vF (Uc=270V)
[H.P.]	[kW]						50	75	100	50	75	100				
0.5	0.37	1500	230	3440	5	13	38	43	44	0.74	0.76	0.78	1.02	1.69	36	100-120
0.75	0.55	1500	230	3440	7	18.5	48	49	50	0.74	0.78	0.80	1.53	2.30	36	100-120
1.0	0.75	1500	230	3450	9.5	24	48	50	52	0.75	0.79	0.81	2.04	3.32	61	100-120
1.5	1.1	1500	230	3450	14	50	50	52	54	0.75	0.77	0.80	3.06	4.9	61	100-120

- PN - Rated Output
- F[N] - Axial Thrust Load
- UN - Rated Voltage
- nN - RPM
- IN - Full Load Current
- IA - Starting Current
- ι - Motor Efficiency
- cosκ - Power Factor
- TN - Full Load Torque
- TA - Starting Torque

Exploded Drawing of 3" W/L Motor

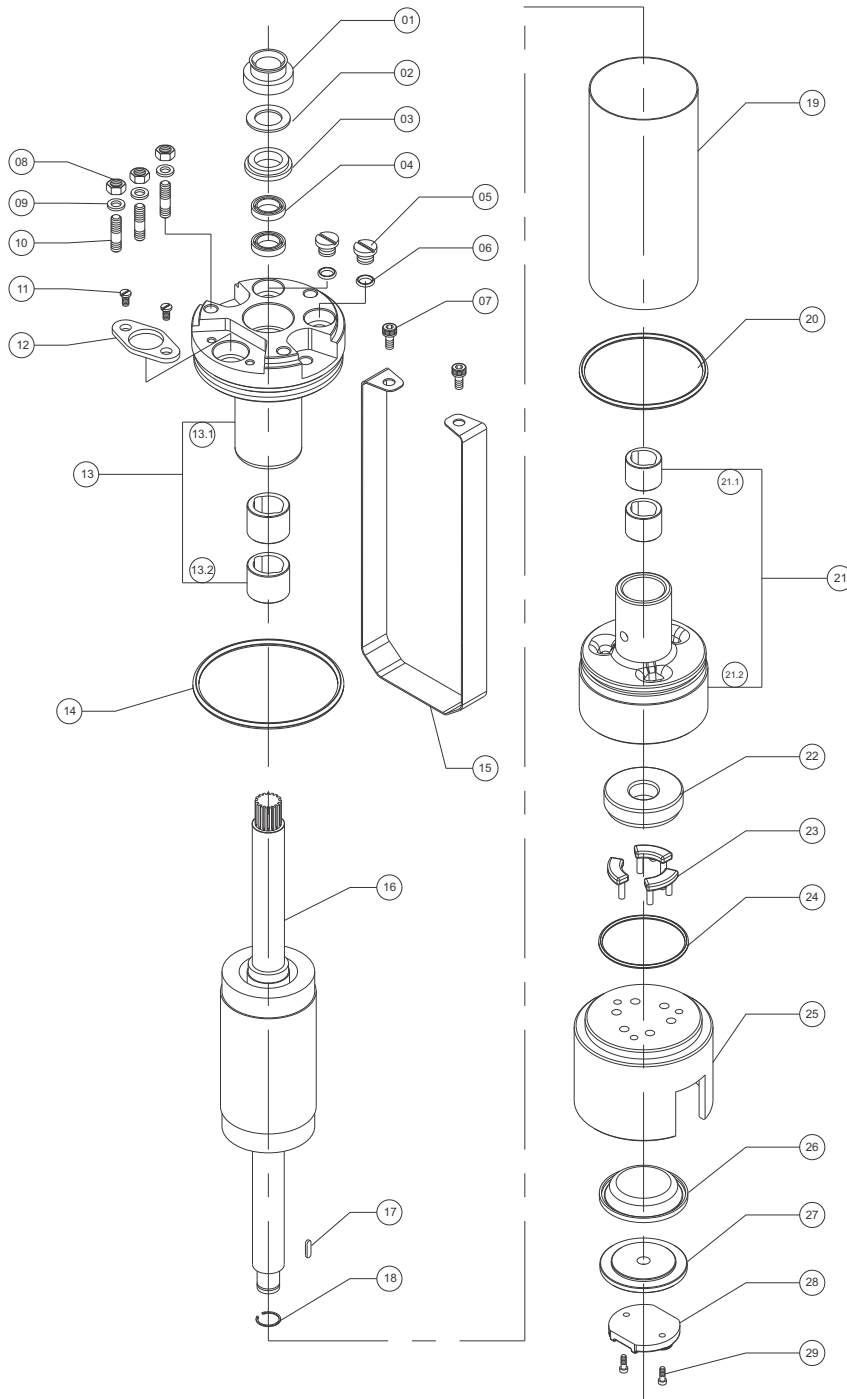

No.	PARTS NAME
1	SAND GUARD
2	TEFLON WASHER
3	OIL SEAL COLLER
4	OIL SEAL
5	DRAIN PLUG
6	DRAIN PLUG 'O' RING
7	ALLEN BOLT (MOTOR PATTI)
8	HEX NUT
9	SPRING WASHER
10	UPPER STUD
11	CABLE CLIP SCREW
12	CABLE CLIP
13	UPPER HOUSING FINISH WITH BUSH
13.1	UPPER HOUSING
13.2	BEARING BUSH
14	O RING
15	CLAMPING STRIP
16	ROTOR SHAFT
17	ROTOR KEY (BEARING SIDE)
18	CIR CLIP
19	STATOR BODY
20	O RING
21	LOWER HOUSING WITH BUSH
21.1	LOWER HOUSING
21.2	BEARING BUSH
22	CARBON PLATE
23	LOOS SEGMENT
24	O RING
25	MOTOR BASE
26	PRESSURE CUP
27	BASE PLATE
28	PULLING PLATE
29	ALLEN BOLT

Submersible Motor

4" OIL LUBRICATED REWINDABLE MOTORS

TECHNICAL SPECIFICATIONS:

- 4" Oil lubricated Motors are rewindable.
- Coupling dimensions as per NEMA standard.
- Winding wires are dual coated Enamelled.
- Insulation class : B.
- Degree of protection : IP58.
- Max oil temperature : 35°C.
- Start per hour : 30 time (Max.).
- Allowable voltage variation : +6% - 10%.
- Motor shaft of Stainless Steel.
- Stator shell of Stainless Steel.
- Max depth immersion : 250M.
- Mounting : Vertical / Horizontal.
- Upper / Lower bracket with Stainless Steel cladding.
- Single Phase Motors are Capacitor start and run.
- Motor Cable length : 3 Meter (3 Core /4 Core).
- Coolant : Die electric non - toxic.

VERSIONS:

Single Phase : 0.25 kW to 2.20 kW, 220 - 230Volt / 50 Hz.

0.37 kW to 2.20 kW, 230Volt / 60 Hz.

Three Phase : 0.37 kW to 5.50 kW, 380 - 400 - 415Volt /50 Hz.

0.37 kW to 4.00 kW, 230 - 380 - 460Volt /60 Hz.

Motor with other voltage and frequency ratings are available on specific demand.

4" O/L REWINDABLE MOTOR

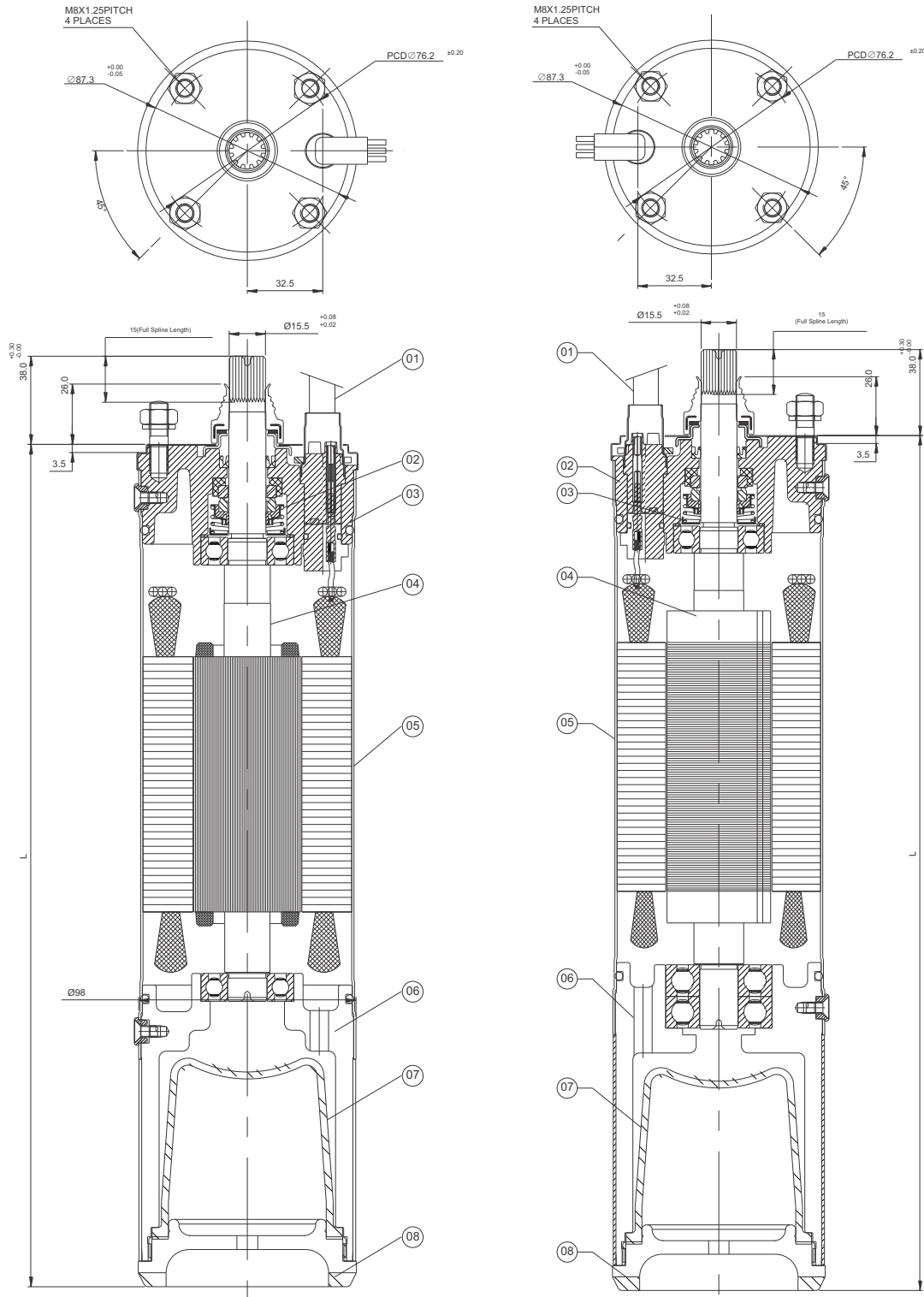

Submersible Motor

SR NO.	PARTS NAME	MATERIAL
01	CABLE 3 CORE / 4 CORE	EPR/PVC
02	MECH. SEAL	CERAMIC / CARBON
03	UPPER HOUSING	CAST IRON with S.S Claded
04	ROTOR SHAFT	S.S.420
05	MOTOR SHELL	S.S.304
06	LOWER HOUSING	CAST IRON with S.S Claded
07	PRESSURE CUP	HBR
08	MOTOR BASE	ENG. PLASTIC
09	ALL HARDWARE	S.S.304

P _N		S.P. L [mm]	MOTOR WEIGHT [kg]	MOTOR WEIGHT (incl.pkg)[kg]
[kW]	[H.P.]			
0.37	0.50	303	6.3	8.30
0.55	0.75	328	6.8	8.80
0.75	1.00	363	8.2	10.2
1.10	1.50	403	9.4	11.4

P _N		T.P. L [mm]	MOTOR WEIGHT [kg]	MOTOR WEIGHT (incl.pkg)[kg]
[kW]	[H.P.]			
0.37	1.00	328	6.8	8.80
0.37	1.00	348	7.5	9.5
1.10	1.50	363	8.2	10.2

P _N		S.P. L [mm]	MOTOR WEIGHT [kg]	MOTOR WEIGHT (incl.pkg)[kg]
[kW]	[H.P.]			
1.50	2.00	468	12.9	14.9
2.20	3.00	498	13.5	15.5
2.20	3.00	528	20.0	22.0

P _N		T.P. L [mm]	MOTOR WEIGHT [kg]	MOTOR WEIGHT (incl.pkg)[kg]
[kW]	[H.P.]			
1.50	2.00	403	11.0	13.0
2.20	3.00	448	12.0	14.0
4.00	5.50	498	13.5	15.5
5.50	7.50	598	22.0	24.0

Technical Data of 4" Motors Single Phase (220-230 Volt / 50 Hz) CSR

PN		Thrust Load [N]	UN [V]	nN [min-1]	IN [A]	IA [A]	η (Eff.) [%] at % load			cos κ (PF) at % load			TN [Nm]	TA [Nm]	Capacitor Running vF (Uc=450V)
[H.P.]	[kW]						50	75	100	50	75	100			
0.33	0.25	1500	220	2860	2.3	7.0	35	46	54	0.85	0.90	0.94	0.81	0.77	25
			230	2870	2.5	8.4	32	43	50	0.78	0.85	0.90	0.81	0.85	
0.50	0.37	1500	220	2850	3.2	10.7	37	49	56	0.88	0.94	0.97	1.22	0.93	25
			230	2860	3.4	11.2	36	46	53	0.81	0.84	0.93	1.22	1.02	
0.75	0.55	1500	220	2840	4.2	15.4	48	58	64	0.90	0.95	0.97	1.86	1.28	36
			230	2855	4.3	16.1	46	56	63	0.82	0.90	0.94	1.86	1.41	
1.00	0.75	1500	220	2840	5.8	20.2	44	55	61	0.96	0.98	0.99	2.46	1.99	36
			230	2855	5.7	21.1	42	53	60	0.90	0.95	0.98	2.46	2.19	
1.50	1.10	3000	220	2840	8.4	30.1	48	57	64	0.90	0.95	0.97	3.70	2.80	40
			230	2855	8.6	31.5	44	54	62	0.82	0.89	0.94	3.70	3.10	
2.00	1.50	3000	220	2805	10.6	33.9	52	62	67	0.91	0.96	0.98	4.97	3.28	50
			230	2825	10.6	35.4	49	59	66	0.82	0.90	0.95	4.97	3.63	
3.00	2.20	4000	220	2810	16.0	54.2	53	61	65	0.94	0.97	0.99	7.42	4.37	80
			230	2840	15.5	56.7	51	61	66	0.86	0.93	0.97	7.42	4.82	

Technical Data of 4" Motors Single Phase (220-230 Volt / 50 Hz) CSCR

PN		Thrust Load [N]	UN [V]	nN [min-1]	IN [A]	IA [A]	η (Eff.) [%] at % load			cos κ (PF) at % load			TN [Nm]	TA [Nm]	Capacitor Running vF (Uc=450V)	Capacitor Starting vF (Uc=270V)
[H.P.]	[kW]						50	75	100	50	75	100				
0.33	0.25	1500	220	2900	2.9	12	45	53	57	0.50	0.60	0.69	0.81	1.37	25	100-120
			230	2900	2.8	11.5	45	53	57	0.50	0.60	0.69	0.81	1.37		
0.50	0.37	1500	220	2890	4.2	15.1	51	59	62	0.52	0.64	0.73	1.2	2	25	100-120
			230	2890	4	14.4	51	59	62	0.52	0.64	0.73	1.2	2		
0.75	0.55	1500	220	2900	6.3	24.1	52	59	63	0.48	0.59	0.69	1.8	2.7	36	100-120
			230	2900	6	23.1	52	59	63	0.48	0.59	0.69	1.8	2.7		
1.00	0.75	1500	220	2890	7.6	29.6	56	62	64	0.54	0.66	0.75	2.5	4.1	36	100-120
			230	2890	7.3	28.3	56	62	64	0.54	0.66	0.75	2.5	4.1		
1.50	1.10	3000	220	2890	9.6	41.4	58	65	68	0.59	0.71	0.80	3.7	6	40	100-120
			230	2890	8.9	39.6	58	65	68	0.59	0.71	0.80	3.7	6		
2.00	1.50	3000	220	2875	11.6	55.8	60	66	68	0.71	0.81	0.88	4.9	8.3	50	100-120
			230	2875	11.1	53.4	60	66	68	0.71	0.81	0.88	4.9	8.3		
3.00	2.20	4000	220	2885	16.7	84	61	68	70	0.72	0.82	0.88	7.4	14	80	100-150
			230	2885	15.9	88	61	68	70	0.72	0.82	0.88	7.4	14		

- PN - Rated Output
- F[N] - Axial Thrust Load
- UN - Rated Voltage
- nN - RPM
- IN - Full Load Current
- IA - Starting Current
- η - Motor Efficiency
- cosκ - Power Factor
- TN - Full Load Torque
- TA - Starting Torque

Submersible Motor

Technical Data of 4" Motors Three Phase(380-415 Volt / 50 Hz)

PN		Thrust F [N]	UN [V]	nN [min-1]	IN [A]	IA [A]	η (Eff.) [%] at % load			cos κ (PF) at % load			TN [Nm]	TA [Nm]
[H.P.]	[kW]						50	75	100	50	75	100		
0.50	0.37	1500	380	2840	1.1	4.4	59	64	66	0.57	0.69	0.76	1.2	2.3
			400	2865	1.1	4.7	56	63	66	0.53	0.65	0.70	1.2	2.5
			415	2875	1.2	4.9	54	62	66	0.49	0.60	0.76	1.2	2.8
0.75	0.55	1500	380	2830	1.6	6.0	61	67	67	0.59	0.72	0.80	1.9	3.1
			400	2855	1.6	6.4	58	64	67	0.54	0.67	0.75	1.9	3.5
			415	2870	1.7	6.6	55	63	66	0.50	0.63	0.80	1.9	3.7
1.00	0.75	1500	380	2850	2.1	8.9	63	68	70	0.57	0.70	0.79	2.5	4.8
			400	2870	2.1	9.3	60	67	69	0.52	0.65	0.75	2.5	5.3
			415	2880	2.2	9.8	57	65	68	0.49	0.61	0.71	2.5	5.9
1.50	1.10	3000	380	2820	3.0	13.8	69	72	72	0.59	0.73	0.81	3.8	9.6
			400	2840	3.0	14.5	66	71	73	0.53	0.67	0.76	3.7	10.6
			415	2860	3.1	15.3	64	70	72	0.49	0.62	0.72	3.7	11.5
2.00	1.50	3000	380	2840	3.9	18.6	69	72	73	0.59	0.72	0.81	5.0	11.3
			400	2855	4.0	19.2	66	71	73	0.53	0.66	0.76	5.0	12.6
			415	2870	4.1	20.2	63	69	72	0.48	0.61	0.72	4.9	13.5
3.00	2.20	4000	380	2815	5.8	28.7	72	75	75	0.58	0.72	0.81	7.6	21.7
			400	2840	5.9	28.9	69	73	75	0.51	0.64	0.75	7.5	23.6
			415	2870	6.3	30.8	66	71	73	0.45	0.59	0.69	7.5	25.9
4.00	3.00	6500	380	2785	6.4	32.0	70	73	75	0.70	0.73	0.76	10.15	23.35
			400	2790	6.3	32.5	69	71	74	0.69	0.72	0.75	10.10	25.25
			415	2810	6.1	33.2	67	70	73	0.67	0.71	0.73	10.00	28.0
5.50	4.00	6500	380	2785	9.70	38.0	70	72	75	0.71	0.73	0.75	13.37	26.56
			400	2790	9.50	40.0	69	70	74	0.69	0.72	0.74	13.34	29.4
			415	2800	9.40	41.5	67	69	73	0.67	0.70	0.73	13.30	32
7.50	5.50	6500	380	2810	13.70	47.0	70	72	75	0.72	0.73	0.75	18.76	37.52
			400	2820	13.50	49.0	69	71	74	0.70	0.71	0.74	18.70	41.14
			415	2840	13.00	51.0	68	70	73	0.68	0.70	0.72	18.56	44.54

Technical Data of 4" Motors Single Phase (220-230 Volt / 60 Hz) CSR

PN		Thrust Load [N]	UN [V]	nN [min-1]	IN [A]	IA [A]	ι (Eff.) [%] at % load			cos κ (PF) at % load			TN [Nm]	TA [Nm]	Capacitor Running vF (Uc=450V)
[H.P.]	[kW]						50	75	100	50	75	100			
0.5	0.37	3000	230	3450	3.1	10.7	43	53	60	0.76	0.79	0.88	1.02	0.86	25
0.75	0.55	3000	230	3450	4.2	15.4	50	60	67	0.83	0.91	0.95	1.53	1.16	36
1.0	0.75	3000	230	3460	5.8	20.2	46	55	62	0.90	0.95	0.98	2.03	1.81	36
1.5	1.1	3000	230	3450	8	30.1	49	59	67	0.81	0.88	0.93	3.06	2.57	40
2.0	1.5	3000	230	3450	10.1	33.9	53	63	70	0.83	0.91	0.96	4.07	2.97	50
3.0	2.2	4000	230	3430	14	54.2	58	68	73	0.87	0.94	0.98	6.15	4.00	80

Technical Data of 4" Motors Single Phase (220-230 Volt / 60 Hz) CSCR

PN		Thrust Load [N]	UN [V]	nN [min-1]	IN [A]	IA [A]	ι (Eff.) [%] at % load			cos κ (PF) at % load			TN [Nm]	TA [Nm]	Capacitor Running ι F (Uc=450V)	Capacitor Starting vF (Uc=270V)
[H.P.]	[kW]						50	75	100	50	75	100				
0.5	0.37	3000	230	3480	4.2	15.2	57	64	67	0.50	0.59	0.68	1.01	1.68	25	100-120
0.75	0.55	3000	230	3485	6.5	24.2	57	65	68	0.49	0.59	0.70	1.51	2.27	36	100-120
1.0	0.75	3000	230	3590	7.8	30	54	62	65	0.53	0.64	0.73	2.01	3.3	36	100-120
1.5	1.1	3000	230	3490	9.6	41.5	60	67	70	0.59	0.70	0.79	3.04	4.92	40	100-120
2.0	1.5	3000	230	3480	11.1	55.3	63	71	74	0.69	0.80	0.89	4.04	6.87	50	100-120
3.0	2.2	4000	230	3475	14.7	82	67	74	77	0.70	0.81	0.89	6.07	11.5	80	120-150

- PN - Rated Output
- F[N] - Axial Thrust Load
- UN - Rated Voltage
- nN - RPM
- IN - Full Load Current
- IA - Starting Current
- ι - Motor Efficiency
- cosκ - Power Factor
- TN - Full Load Torque
- TA - Starting Torque

Submersible Motor

Technical Data of 4" Motors Three Phase / 60 Hz

P _N		Thrust Load [N]	U _N [V]	n _N [min ⁻¹]	I _N [A]	I _A [A]	η (Eff.) [%] at % load			cos κ (PF) at % load			T _N [Nm]	T _A [Nm]
[H.P.]	[kW]						50	75	100	50	75	100		
0.5	0.37	3000	230	3445	2.41	9.6	59	62	64	0.58	0.71	0.79	1.02	1.84
			380	3445	1.42	5.6	59	62	64	0.58	0.71	0.79	1.02	1.96
			460	3445	1.21	4.8	59	62	64	0.58	0.71	0.79	1.02	2.24
0.75	0.55	3000	230	3450	3.10	12.4	63	67	69	0.57	0.71	0.80	1.53	2.3
			380	3450	1.91	7.6	63	67	69	0.57	0.71	0.80	1.53	2.5
			460	3450	1.60	6.4	63	67	69	0.57	0.71	0.80	1.53	2.75
1.0	0.75	3000	230	3455	3.91	17.55	65	68	70	0.59	0.72	0.81	2.03	3.55
			380	3455	2.32	10.35	65	68	70	0.59	0.72	0.81	2.03	3.90
			460	3455	2.00	9	65	68	70	0.59	0.72	0.81	2.03	4.47
1.5	1.1	3000	230	3445	5.00	25	70	73	76	0.61	0.76	0.83	3.04	6.69
			380	3445	3.00	15	70	73	76	0.61	0.76	0.83	3.04	7.7
			460	3445	2.51	12.5	70	73	76	0.61	0.76	0.83	3.04	8.2
2.0	1.5	3000	230	3445	6.71	33.5	64	66	69	0.59	0.73	0.81	4.08	8.16
			380	3445	4.11	20.5	64	66	69	0.59	0.73	0.81	4.08	9.22
			460	3445	3.40	17	64	66	69	0.59	0.73	0.81	4.08	10.2
3.0	2.2	4000	230	3450	9.51	47.5	70	73	75	0.52	0.65	0.74	6.11	15.3
			380	3450	5.80	29	70	73	75	0.52	0.65	0.74	6.11	17.4
			460	3450	4.82	24	70	73	75	0.52	0.65	0.74	6.11	18.33
5.5	4.0	6500	230	3450	15.91	55.65	69	71	74	0.52	0.66	0.75	11.2	18.50
			380	3450	9.62	33.6	69	71	74	0.52	0.66	0.75	11.2	22.18
			460	3450	8.00	28	69	71	74	0.52	0.66	0.75	11.2	25.80

- P_N - Rated Output
- F[N] - Axial Thrust Load
- U_N - Rated Voltage
- n_N - RPM
- I_N - Full Load Current
- I_A - Starting Current
- η - Motor Efficiency
- cos κ - Power Factor
- T_N - Full Load Torque
- T_A - Starting Torque

Exploded Drawing of 4" O/L Motor

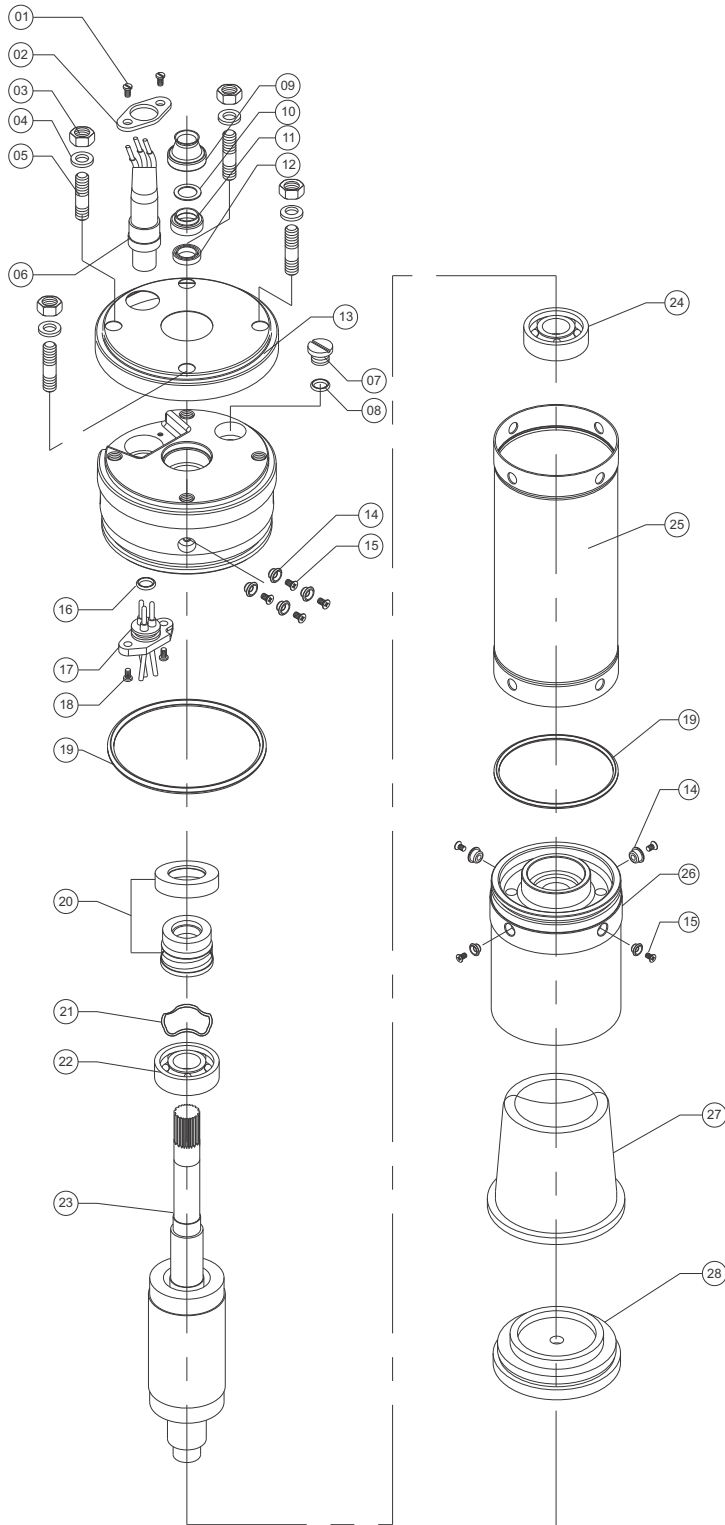

No.	PARTS NAME
1	CABLE CLIP SCREW
2	CABLE CLIP
3	HEX NUT
4	STUD WASHER
5	UPPER STUD
6	CABLE SET
7	DRAIN PLUG
8	DRAIN PLUG 'O' RING
9	SAND GUARD(WITH INSTERT)
10	TEFLON WASHER
11	UPPER CAP
12	OIL SEAL
13	UPPER JACKET
14	SCREW COLLAR
15	SCREW (FOR COLLAR)
16	CABLE CONNECTOR PIN 'O' RING
17	CABLE CONNECTOR PIN
18	CABLE CONNECTOR PIN SCREW
19	'O' RING
20	MECHANICAL SEAL
21	WAVE WASHER
22	BALL BEARING (UPPER SIDE)
23	ROTOR
24	BALL BEARING (LOWER SIDE)
25	STATOR BODY
26	LOWER HOUSING
27	PRESSURE CUP
28	MOTOR BASE PLATE

Submersible Motor

4" WATER LUBRICATED REWINDABLE MOTORS

TECHNICAL SPECIFICATIONS:

- 4" Water Lubricated Motors are rewindable.
- Coupling dimensions as per NEMA standard.
- Winding wire : Polywrapped.
- Degree of protection : IP68.
- Max water temperature : 35° C.
- Start per hour : 30 time (Max.).
- Allowable voltage variation +6% - 10%.
- Motor shaft of Stainless Steel.
- Stator shell of Stainless Steel.
- Max depth immersion : 250 M.
- Mounting : vertical / horizontal.
- Upper / Lower bracket in Cast Iron with Epoxy Paint OR
- Upper Bracket Steel Cast/ Lower bracket with SS Cladding.
- Single Phase Motors are Capacitor start and run.
- Motor Cable length : 3 Meter (3 Core / 4 Core).
- Coolant : Clear Water.

VERSIONS:

Single Phase : 0.37 kW to 4.00 kW, 220 - 230Volt / 50 Hz.

0.37 kW to 4.00 kW, 230Volt / 60 Hz.

Three Phase : 0.55 kW to 7.50 kW, 380 - 415Volt / 50 Hz.

0.37 kW to 7.50 kW, 230 - 380 - 460Volt /60 Hz.

Motors with other Voltage and frequency ratings are also available on specific demand.

4" W/L REWINDABLE MOTOR

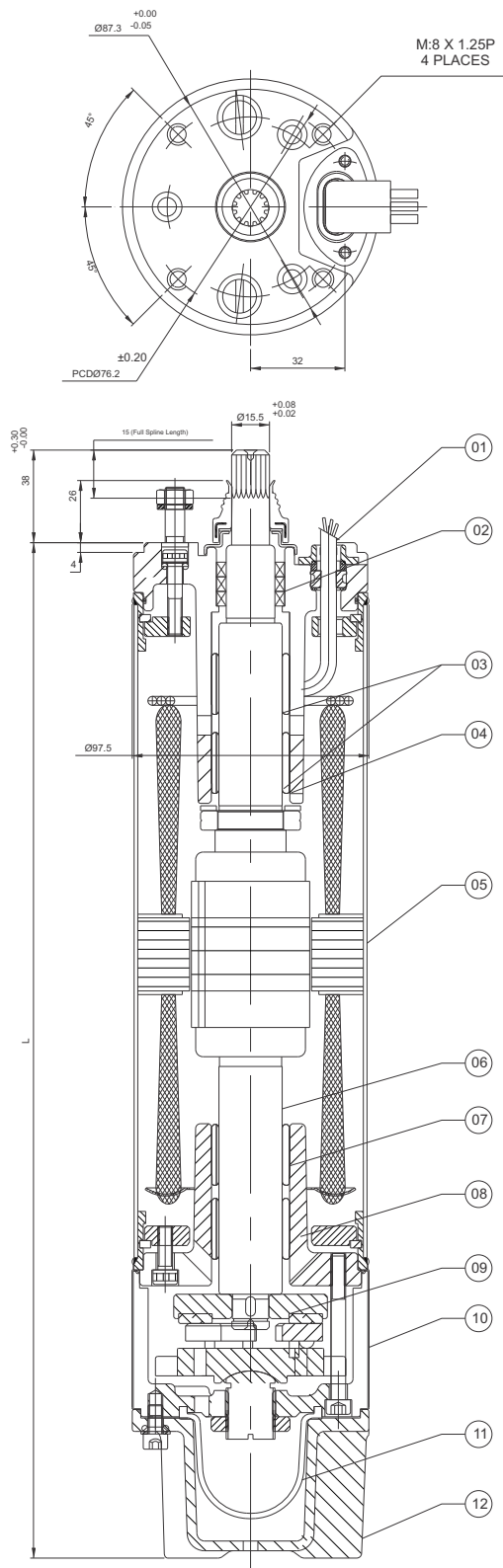

Submersible Motor

SR NO.	PARTS NAME	MATERIAL
01	CABLE 3 CORE/4 CORE	EPR
02	OIL SEAL	N.B.R
03	BEARING BUSH	CARBON
04	UPPER HOUSING	S.S 304/ CAST IRON (F.G 200) / CLADED
05	MOTOR SHELL	S.S.304
06	ROTOR SHAFT	S.S.431
07	BEARING BUSH	CARBON
08	LOWER HOUSING	CAST IRON (FG-200)
09	THRUST BEARING SET	CARBON / S.S 420
10	LOWER PART-2	CAST IRON / CLADED
11	PRESSURE CUP	HBR
12	MOTOR BASE	S.S.304/CAST IRON (F.G 200)
13	ALL HARDWARE	S.S.304

P _N		PW L [mm] C.I. / S.S.	MOTOR WEIGHT [kg]		MOTOR WEIGHT (incl.pkg) [kg]	
[kW]	[HP] (S.P)		S.S. 304	Cast Iron	S.S. 304	Cast Iron
0.37	0.50	526	12.0	12.2	13.8	15.7
0.55	0.75	526	12.0	12.2	13.8	15.7
0.75	1.00	541	12.5	12.6	14.2	16.2
1.10	1.50	556	12.8	13.2	14.7	16.7
1.50	2.00	641	20.6	21.7	23.7	24.0
2.20	3.00	691	23.2	24.3	26.0	27.0
3.70	5.00	911	36.2	38.4	40.5	42.0

P _N		PW L [mm] C.I. / S.S.	MOTOR WEIGHT [kg]		MOTOR WEIGHT (incl.pkg) [kg]	
[kW]	[HP] (T.P)		S.S. 304	Cast Iron	S.S. 304	Cast Iron
0.37	0.50	566	12.9	13.2	15.0	17.0
0.55	0.75	566	12.9	13.2	15.0	17.0
0.75	1.00	601	16.9	17.2	20.2	22.2
1.10	1.50	601	16.9	17.2	20.2	22.2
1.50	2.00	621	20.0	21.0	23.0	24.0
2.20	3.00	671	22.5	23.6	25.2	26.2
3.70	5.00	771	33.5	35.4	38.0	39.0
5.50	7.50	911	36.2	38.4	40.5	43.0
7.50	10.00	966	38.4	40.7	42.9	45.6

Technical Data of 4" Motors Single Phase (220-230 Volt / 50 Hz) CSR

PN		Thrust Load [N]	UN [V]	nN [min-1]	IN [A]	IA [A]	η [%]			cos κ			TN [Nm]	TA [Nm]	Capacitor Running F (Uc=450V)
[H.P.]	[kW]						50	75	100	50	75	100			
0.50	0.37	1500	220	2855	3.21	10.6	37	49	56	0.89	0.93	0.96	1.21	0.93	72
			230	2860	3.40	11.3	36	47	54	0.82	0.84	0.93	1.21	1.02	
0.75	0.55	1500	220	2845	4.19	15.38	47	58	64	0.91	0.94	0.97	1.86	1.28	72
			230	2855	4.29	16.11	46	57	64	0.82	0.91	0.93	1.86	1.42	
1.00	0.75	1500	220	2845	5.79	20.21	45	56	61	0.95	0.98	0.99	2.45	1.99	72
			230	2855	5.70	21.10	43	53	61	0.91	0.96	0.98	2.45	2.19	
1.50	1.10	3000	220	2850	8.41	30.11	47	58	64	0.91	0.95	0.98	3.70	2.81	72
			230	2855	8.58	31.50	44	54	63	0.82	0.90	0.95	3.70	3.10	
2.00	1.50	3000	220	2805	10.59	33.91	52	62	68	0.92	0.95	0.98	4.97	3.28	72
			230	2825	10.59	35.38	50	59	67	0.81	0.90	0.96	4.97	3.62	
3.00	2.20	4000	220	2815	16.00	54.1	52	60	64	0.95	0.96	0.99	7.41	4.37	108
			230	2840	15.51	56.6	51	62	66	0.85	0.92	0.97	7.41	4.82	
4.00	3.00	4000	220	2810	20.1	72	55	61	66	0.94	0.96	0.96	10	6	108
			230	2830	20.0	74	52	61	67	0.85	0.93	0.97	9.94	6.5	
5.50	4.00	4000	220	2815	25.5	92.0	55	62	67	0.95	0.96	0.97	13.7	8.90	108
			230	2830	25.2	95.7	53	62	67	0.86	0.94	0.98	13.6	8.98	

Technical Data of 4" Motors Single Phase (220-230 Volt / 50 Hz) CSCR

PN		Thrust Load [N]	UN [V]	nN [min-1]	IN [A]	IA [A]	η (Eff.) [%] at % load			cos κ (PF) at % load			TN [Nm]	TA [Nm]	Capacitor Running vF (Uc=450V)	Capacitor Starting vF (Uc=270V)
[H.P.]	[kW]						50	75	100	50	75	100				
0.50	0.37	1500	220	2890	4.21	15.11	50	60	62	0.51	0.64	0.74	1.21	2	72	100-120
			230	2890	4.00	14.30	50	60	62	0.51	0.64	0.74	1.21	2		
0.75	0.55	1500	220	2895	6.29	24.11	51	59	63	0.49	0.60	0.69	1.79	2.7	72	100-120
			230	2895	6.00	23.00	51	59	63	0.49	0.60	0.69	1.79	2.7		
1.00	0.75	1500	220	2890	7.59	29.5	55	63	64	0.55	0.66	0.76	2.51	4.1	72	100-120
			230	2890	7.31	28.2	55	63	64	0.55	0.66	0.76	2.51	4.1		
1.50	1.10	3000	220	2890	9.58	41.3	57	66	68	0.58	0.72	0.80	3.69	6.0	72	100-120
			230	2890	8.90	39.5	57	66	68	0.58	0.72	0.80	3.69	6.0		
2.00	1.50	3000	220	2880	11.58	55.7	61	67	68	0.70	0.82	0.88	4.89	8.28	72	100-120
			230	2880	11.10	53.5	61	67	68	0.70	0.82	0.88	4.89	8.28		
3.00	2.20	4000	220	2885	16.71	83	62	68	70	0.71	0.81	0.88	7.41	14	108	120-150
			230	2885	15.89	87	62	68	70	0.71	0.81	0.88	7.41	14		
4.00	3.00	4000	220	2885	20.6	103	62	68	71	0.73	0.82	0.88	9.75	18.5	108	120-150
			230	2885	20.3	112	62	68	71	0.73	0.82	0.88	9.75	18.5		
5.50	4.00	4000	220	2885	25.8	129	63	69	71	0.74	0.82	0.89	13.4	24.1	108	120-150
			230	2885	25.6	141	63	69	71	0.74	0.82	0.89	13.4	24.1		

- PN - Rated Output
- UN - Rated Voltage
- nN - RPM
- IN - Full Load Current
- IA - Starting Current
- η - Motor Efficiency
- cos κ - Power Factor
- TN - Full Load Torque
- TA - Starting Torque
- F{N} - Axial Thrust Load

Submersible Motor

Technical Data of 4" Motors Three Phase (380-415 Volt / 50 Hz)

PN		Thrust F [N]	UN [V]	nN [min-1]	IN [A]	IA [A]	η (Eff.) [%] at % load			cos κ (PF) at % load			TN [Nm]	TA [Nm]
[H.P.]	[kW]						50	75	100	50	75	100		
0.75	0.55	1500	380	2835	1.59	6.00	60	66	67	0.60	0.72	0.81	1.89	3.11
			400	2855	1.59	6.38	58	65	67	0.54	0.68	0.75	1.89	3.51
			415	2875	1.70	6.61	55	64	66	0.50	0.64	0.80	1.89	3.70
1.00	0.75	1500	380	2845	2.11	8.88	64	67	70	0.58	0.71	0.79	2.50	4.81
			400	2870	2.11	9.30	60	68	69	0.51	0.64	0.75	2.50	5.32
			415	2880	2.20	9.81	58	65	68	0.49	0.61	0.72	2.50	5.89
1.50	1.10	3000	380	2825	3.00	13.70	68	72	73	0.58	0.72	0.81	3.79	9.61
			400	2840	3.00	14.51	67	71	73	0.53	0.67	0.75	3.69	10.60
			415	2860	3.11	15.28	65	70	72	0.50	0.62	0.72	3.69	11.49
2.00	1.50	3000	380	2845	3.91	18.59	68	72	73	0.60	0.72	0.81	5.0	11.31
			400	2855	4.00	19.21	66	72	73	0.54	0.66	0.77	5.0	12.60
			415	2870	4.10	20.21	64	70	72	0.49	0.62	0.73	4.9	13.49
3.00	2.20	4000	380	2820	5.80	28.68	71	75	75	0.59	0.72	0.81	7.59	21.71
			400	2840	5.91	28.90	70	73	75	0.51	0.65	0.76	7.51	23.61
			415	2870	6.29	30.78	66	71	74	0.46	0.60	0.69	7.51	25.90
4.00	3.00	4000	380	2810	8.5	29.5	62	67	70	0.72	0.78	0.82	10	16
			400	2820	8.2	31.0	61	66	68	0.71	0.77	0.80	9.97	17.95
			415	2850	8.0	33.0	60	65	67	0.70	0.76	0.80	9.87	18.75
5.50	4.00	4000	380	2790	10.79	32.29	62	67	71	0.72	0.79	0.83	13.39	21.25
			400	2790	10.51	34.00	61	65	69	0.70	0.76	0.82	13.30	23.54
			415	2810	10.0	35.00	59	64	66	0.69	0.74	0.82	13.30	25.29
7.50	5.50	4000	380	2785	14.79	50.4	69	73	74	0.74	0.79	0.84	18.93	37.19
			400	2790	14.51	53.0	68	72	73	0.74	0.79	0.84	18.92	41.21
			415	2810	14.00	54.9	67	69	71	0.73	0.77	0.83	18.81	44.35
10.0	7.50	4000	380	2855	18.00	61.1	70	72	73	0.98	0.95	0.92	24.58	45.10
			400	2860	18.31	62.0	67	71	72	0.99	0.94	0.91	24.51	46.00
			415	2880	18.79	65.9	66	68	70	0.97	0.92	0.88	24.40	47.51

- PN - Rated Output
- UN - Rated Voltage
- nN- RPM
- IN - Full Load Current
- IA - Starting Current
- η - Motor Efficiency
- cosκ - Power Factor
- TN - Full Load Torque
- TA - Starting Torque
- F{N}- Axial Thrust Load

Technical Data of 4" Motors Single Phase / 60 Hz (CSR)

PN		Thrust Load [N]	UN [V]	nN [min-1]	IN [A]	IA [A]	ι (Eff.) [%] at % load			cos κ (PF) at % load			TN [Nm]	TA [Nm]	Capacitor Running vF (Uc=450V)
[H.P.]	[kW]						50	75	100	50	75	100			
0.5	0.37	3000	230	3450	4.2	10.7	43	53	60	0.76	0.79	0.88	1.02	0.86	72
0.75	0.55	3000	230	3450	5	15.4	50	60	67	0.83	0.91	0.95	1.53	1.16	72
1.0	0.75	3000	230	3460	7	20.2	46	55	62	0.90	0.95	0.98	2.03	1.81	72
1.5	1.1	3000	230	3450	9.5	30.1	49	59	67	0.81	0.88	0.93	3.06	2.57	72
2.0	1.5	3000	230	3450	12	33.9	53	63	70	0.83	0.91	0.96	4.07	2.97	72
3.0	2.2	4000	230	3430	16	54.2	58	68	73	0.87	0.94	0.98	6.15	4.00	108

- PN - Rated Output
- UN - Rated Voltage
- nN - RPM
- IN - Full Load Current
- IA - Starting Current
- ι - Motor Efficiency
- cosκ - Power Factor
- TN - Full Load Torque
- TA - Starting Torque
- F(N) - Axial Thrust Load

Technical Data of 4" Motors Single Phase / 60 Hz (CSCR)

PN		Thrust Load [N]	UN [V]	nN [min-1]	IN [A]	IA [A]	ι (Eff.) [%] at % load			cos κ (PF) at % load			TN [Nm]	TA [Nm]	Capacitor Running ι F (Uc=450V)	Capacitor Starting vF (Uc=270V)
[H.P.]	[kW]						50	75	100	50	75	100				
0.5	0.37	3000	230	3480	4.2	15.2	57	64	67	0.50	0.59	0.68	1.01	1.68	72	100-120
0.75	0.55	3000	230	3485	6.5	24.2	57	65	68	0.49	0.59	0.70	1.51	2.27	72	100-120
1.0	0.75	3000	230	3490	7.8	30	54	62	65	0.53	0.64	0.73	2.01	3.3	72	100-120
1.5	1.1	3000	230	3490	9.6	41.5	60	67	70	0.59	0.70	0.79	3.04	4.92	72	100-120
2.0	1.5	3000	230	3480	12.5	55.3	63	71	74	0.69	0.80	0.89	4.04	6.87	72	100-120
3.0	2.2	4000	230	3475	16.5	82	67	74	77	0.70	0.81	0.89	6.07	11.5	108	120-150
5.5	4.0	4000	230	3450	26.0	130	68	74	77	0.70	0.82	0.98	11.2	21.2	108	200-250

- PN - Rated Output
- UN - Rated Voltage
- nN - RPM
- IN - Full Load Current
- IA - Starting Current
- ι - Motor Efficiency
- cosκ - Power Factor
- TN - Full Load Torque
- TA - Starting Torque
- F(N) - Axial Thrust Load

Submersible Motor

Technical Data of 4" Motors Three Phase / 60 Hz

PN		Thrust Load [N]	UN [V]	nN [min-1]	IN [A]	IA [A]	η (Eff.) [%] at % load			cos κ (PF) at % load			TN [Nm]	TA [Nm]
[H.P.]	[kW]						50	75	100	50	75	100		
0.5	0.37	3000	230	3445	2.41	9.6	59	62	64	0.58	0.71	0.79	1.02	1.84
			380	3445	1.42	5.6	59	62	64	0.58	0.71	0.79	1.02	1.96
			460	3445	1.21	4.8	59	62	64	0.58	0.71	0.79	1.02	2.24
0.75	0.55	3000	230	3450	3.10	12.4	63	67	69	0.57	0.71	0.80	1.53	2.3
			380	3450	1.91	7.6	63	67	69	0.57	0.71	0.80	1.53	2.5
			460	3450	1.60	6.4	63	67	69	0.57	0.71	0.80	1.53	2.75
1.0	0.75	3000	230	3455	3.91	17.55	65	68	70	0.59	0.72	0.81	2.03	3.55
			380	3455	2.32	10.35	65	68	70	0.59	0.72	0.81	2.03	3.9
			460	3455	2.00	9	65	68	70	0.59	0.72	0.81	2.03	4.47
1.5	1.1	3000	230	3445	5.00	25	70	73	76	0.61	0.76	0.83	3.04	6.69
			380	3445	3.00	15	70	73	76	0.61	0.76	0.83	3.04	7.7
			460	3445	2.51	12.5	70	73	76	0.61	0.76	0.83	3.04	8.2
2.0	1.5	3000	230	3445	6.71	33.5	64	66	69	0.59	0.73	0.81	4.08	8.16
			380	3445	4.11	20.5	64	66	69	0.59	0.73	0.81	4.08	9.22
			460	3445	3.40	17	64	66	69	0.59	0.73	0.81	4.08	10.2
3.0	2.2	4000	230	3450	9.51	47.5	70	73	75	0.52	0.65	0.74	6.11	15.3
			380	3450	5.80	29	70	73	75	0.52	0.65	0.74	6.11	17.4
			460	3450	4.82	24	70	73	75	0.52	0.65	0.74	6.11	18.33
5.5	4.0	6500	230	3450	15.91	55.65	69	71	74	0.52	0.66	0.75	11.2	15.70
			380	3450	9.62	33.6	69	71	74	0.52	0.66	0.75	11.2	17.70
			460	3450	8.00	28	69	71	74	0.52	0.66	0.75	11.2	19.04
7.5	5.5	6500	230	3445	23.0	92	71	73	76	0.56	0.68	0.77	15.30	22.95
			380	3445	13.91	55.6	71	73	76	0.56	0.68	0.77	15.30	30.00
			460	3445	11.51	46	71	73	76	0.56	0.68	0.77	15.30	33.70
10.0	7.5	6500	230	3450	27.1	95	70	73	75	0.58	0.71	0.80	20.4	32.64
			380	3450	19.29	67.55	70	73	75	0.58	0.71	0.80	20.4	37.33
			460	3450	15.91	55.65	70	73	75	0.58	0.71	0.80	20.4	44.90

- PN - Rated Output
- UN - Rated Voltage
- nN - RPM
- IN - Full Load Current
- IA - Starting Current
- η - Motor Efficiency
- cos κ - Power Factor
- TN - Full Load Torque
- TA - Starting Torque
- F(N) - Axial Thrust Load

Submersible Motor

5" REWINDABLE MOTORS

TECHNICAL SPECIFICATIONS:

- 5" Water Lubricated Submersible Motors are rewindable.
- Coupling dimensions as per NEMA standard.
- Winding wire : Polywrapped / PVC winding available on specific demand
- Degree of protection : IP68.
- Max water temperature : 35°C.
- Starts per hour : 20 time (Max.).
- Allowable voltage variation : +6% - 10%.
- Motor shaft of Stainless steel.
- Stator shell of Stainless steel.
- Max depth immersion : 350 M.
- Mounting : vertical / horizontal.
- Motor Cable length : 3 Meter / 3 Core with separate earth cable & 4 Core.
- Cooling Flow : V:0.2 M/S.
- Coolant : Clear Water.

VERSIONS:

Three Phase : 1.1 kw to 9.3 kw / 380-415 Volt /50 Hz

2.2 kw to 9.3 kw / 380-460 Volt /60 Hz.

Motor With Other Voltage and frequency ratings are available on specific Demand.

5" REWINDABLE MOTOR

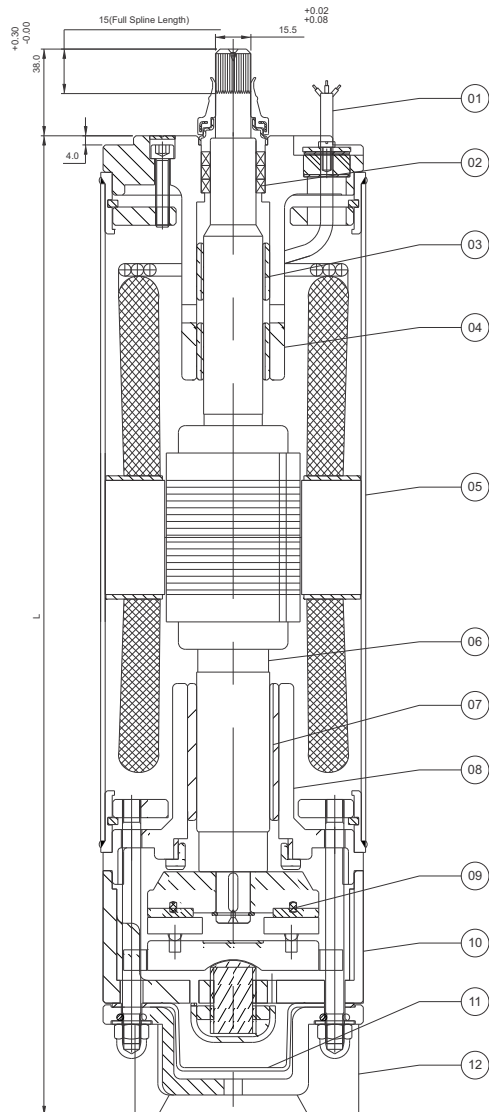
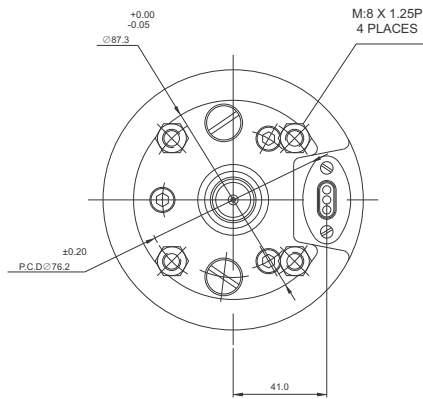

SR.NO.	PARTS NAME	MATERIAL
01	CABLE 3 CORE/4 CORE	EPR
02	OIL SEAL	N.B.R
03	BEARING BUSH	L.T.B-4 2%Ni
04	UPPER HOUSING	CAST IRON (F.G 200)
05	MOTOR SHELL	S.S.202
06	ROTOR SHAFT	S.S.420
07	BEARING BUSH	L.T.B-4 (2%NI)
08	LOWER HOUSING	CAST IRON (FG-200)
09	THRUST BEARING SET	CARBON / S.S 420
10	LOWER PART-2	CAST IRON (FG-200)
11	PRESSURE CUP	H.B.R
12	MOTOR BASE	CAST IRON (FG-200)
13	ALL HARDWARE	S.S.304

P _N		PW L[mm] C.I	Motor Weight [kg]	Motor Weight (incl.pkg)[kg]
[kw]	[HP] (T.P)			
1.10	1.50	520.00	21.9	23.9
1.50	2.00	545.00	23.0	25.0
2.20	3.00	565.00	23.9	25.9
2.94	4.00	565.00	23.9	25.9
4.00	5.50	630.00	26.7	28.7
5.50	7.50	695.00	29.5	31.5
7.50	10.00	815.00	34.6	36.6
9.30	12.50	880.00	37.3	39.3

Submersible Motor

Technical Data of 5" Motors / 50 Hz

PN		Thrust F [N]	UN [V]	nN [min-1]	IN [A]	IA [A]	η(Eff.) [%] at % load			COS φ (PF) At % load			TN [Nm]	TA [Nm]
[H.P.]	[kW]						50	75	100	50	75	100		
1.50	1.10	4000	380	2860	3.20	15.0	68	71	71	0.62	0.70	0.71	3.69	9.22
			400	2870	3.30	15.7	67	71	72	0.60	0.67	0.72	3.67	9.35
			415	2870	3.40	16.3	65	70	72	0.55	0.65	0.72	3.67	9.60
2.00	1.50	4000	380	2860	4.10	19.5	70	72	73	0.60	0.70	0.78	4.91	11.80
			400	2865	4.20	20.2	66	72	73	0.55	0.66	0.77	4.90	11.85
			415	2870	4.30	20.6	66	70	72	0.52	0.62	0.75	4.89	11.93
3.00	2.20	15500	380	2865	6.00	21.0	68	69	72	0.66	0.70	0.70	7.36	13.25
			400	2870	6.15	21.8	67	68	71	0.65	0.70	0.69	7.34	13.60
			415	2875	6.25	22.5	66	67	70	0.64	0.69	0.68	7.33	13.90
4.00	3.00	15500	380	2860	9.00	31.5	70	70	72	0.65	0.70	0.72	9.83	17.70
			400	2875	9.20	32.8	69	70	72	0.64	0.69	0.70	9.78	18.00
			415	2875	9.30	33.6	69	68	71	0.64	0.69	0.69	9.78	18.40
5.50	4.00	15500	380	2870	10.20	35.7	70	70	72	0.68	0.70	0.73	13.47	24.90
			400	2875	10.40	37.0	69	70	71	0.66	0.69	0.71	13.44	25.00
			415	2875	10.60	37.4	69	68	71	0.65	0.70	0.71	13.44	25.54
7.50	5.50	15500	380	2875	13.40	46.9	71	72	73	0.70	0.71	0.75	18.33	34.80
			400	2880	13.20	46.9	70	69	72	0.69	0.70	0.75	18.30	35.90
			415	2885	13.10	47.2	70	70	72	0.69	0.70	0.74	18.27	36.50
10.0	7.50	15500	380	2880	18.10	63.4	70	72	74	0.72	0.74	0.75	24.40	46.40
			400	2885	17.50	63.9	70	73	75	0.71	0.72	0.75	24.36	46.77
			415	2885	17.50	64.0	69	70	73	0.70	0.72	0.74	24.36	47.80
12.5	9.30	15500	380	2880	20.50	73.0	72	72	74	0.74	0.74	0.75	30.50	57.90
			400	2885	20.40	74.5	71	73	75	0.72	0.72	0.75	30.45	58.50
			415	2885	20.20	74.7	70	71	73	0.70	0.71	0.74	30.45	59.40

- PN - Rated Output
- UN - Rated Voltage
- nN - RPM
- IN - Full Load Current
- IA - Starting Current
- η - Motor Efficiency
- cosφ - Power Factor
- TN - Full Load Torque
- TA - Starting Torque
- F[N] - Axial Thrust Load

Exploded Drawing of 5" Motor

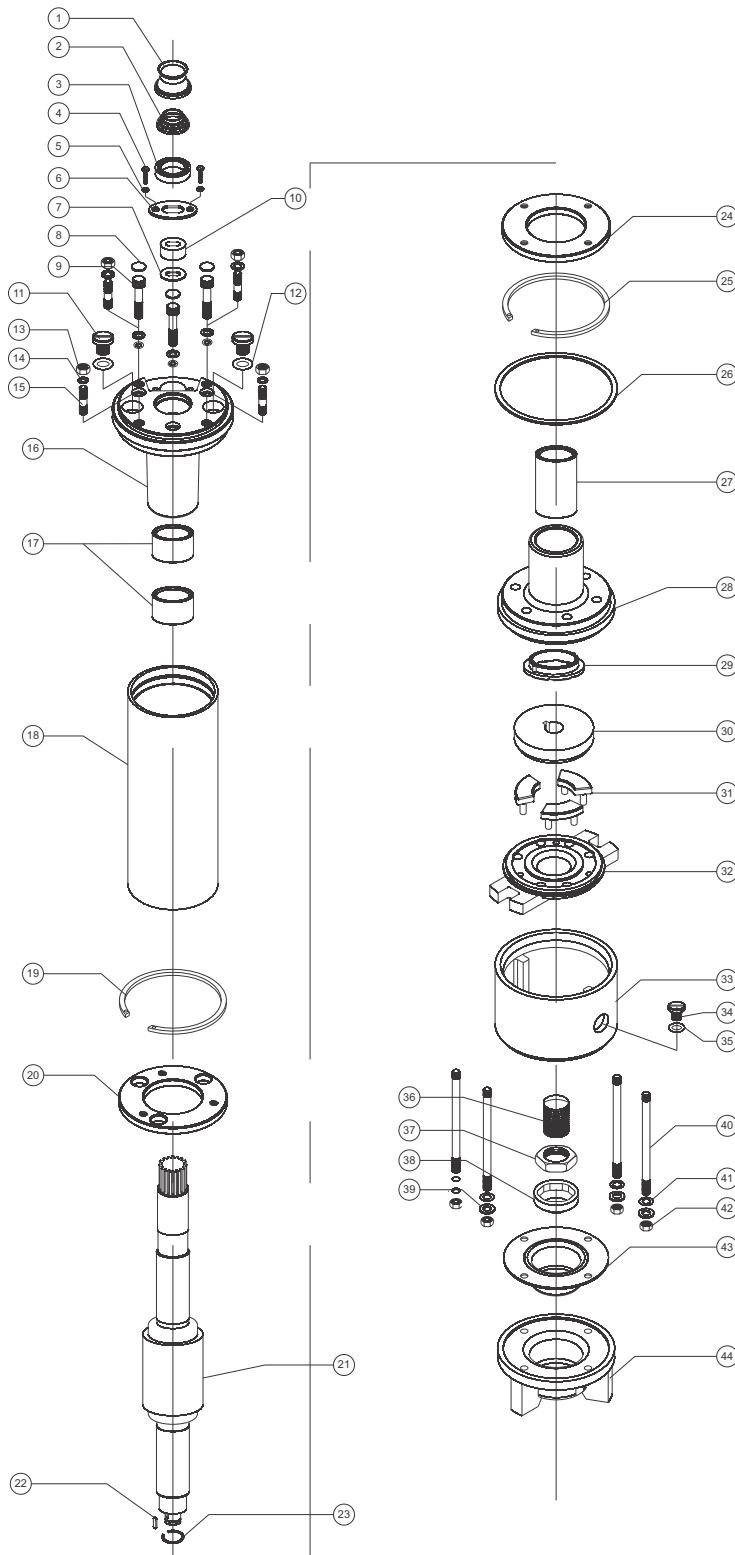

No.	PARTS NAME
1	SAND GUARD
2	UPPER CAP
3	OIL SEAL
4	CABLE CLIP SCREW
5	CABLE CLIP SCREW WASHER
6	CABLE CLIP
7	CABLE GROMMET WASHER
8	ALLEN BOLT CAP
9	ALLEN BOLT
10	CABLE GROMMET
11	DRAIN PLUG
12	DRAIN PLUG 'O' RING
13	HEX NUT
14	UPPER STUD WASHER
15	UPPER STUD
16	UPPER HOUSING
17	BEARING BUSH
18	STATOR BODY
19	CIR CLIP
20	UPPER FLANGE
21	ROTOR
22	ROTOR KEY
23	ROTOR CIR CLIP
24	LOWER FLANGE
25	CIR CLIP
26	PAPER GASKET
27	BEARING BUSH
28	LOWER HOUSING
29	C.T BEARING
30	CARBON BEARING
31	SEGMENT
32	COUNTER
33	LOWER PART-2
34	DRAIN PLUG
35	DRAIN PLUG 'O' RING
36	ROCKER
37	ROCKER LOCK NUT
38	ROCKER LOCK NUT CAP
39	STUD WASHER
40	LOWER STUD
41	STUD 'O' RING
42	HEX NUT
43	PRESSURE CUP
44	MOTOR BASE

Submersible Motor

6" REWINDABLE MOTORS

TECHNICAL SPECIFICATIONS:

- 6" Water Lubricated Submersible Motors are rewindable.
- Coupling dimensions as per NEMA standard.
- Winding wire : Polywrapped / PVC winding available on specific demand
- Degree of protection : IP68.
- Max water temperature : 35° C.
- Starts per hour : 30 times (Max.).
- Allowable voltage variation : +6% - 10%.
- Motor shaft of Stainless steel.
- Stator shell of Stainless steel.
- Max depth immersion : 350 M.
- Mounting : vertical / horizontal.
- Motor Cable length : 3 Meter / 3 Core with separate earth cable & 4 Core.
- Cooling Flow : $V=0.2$ M/S.
- Coolant : Clear Water.

VERSIONS:

Three Phase : 2.20 kW To 37.5 kW / 380-415 Volt/ 50 Hz.

2.20 kW To 37.5 kW/ 230 - 380 - 460Volt /60 Hz.

Motors with other Voltage and frequency ratings are available on specific Demand.

6" REWINDABLE MOTOR

MOTOR-A

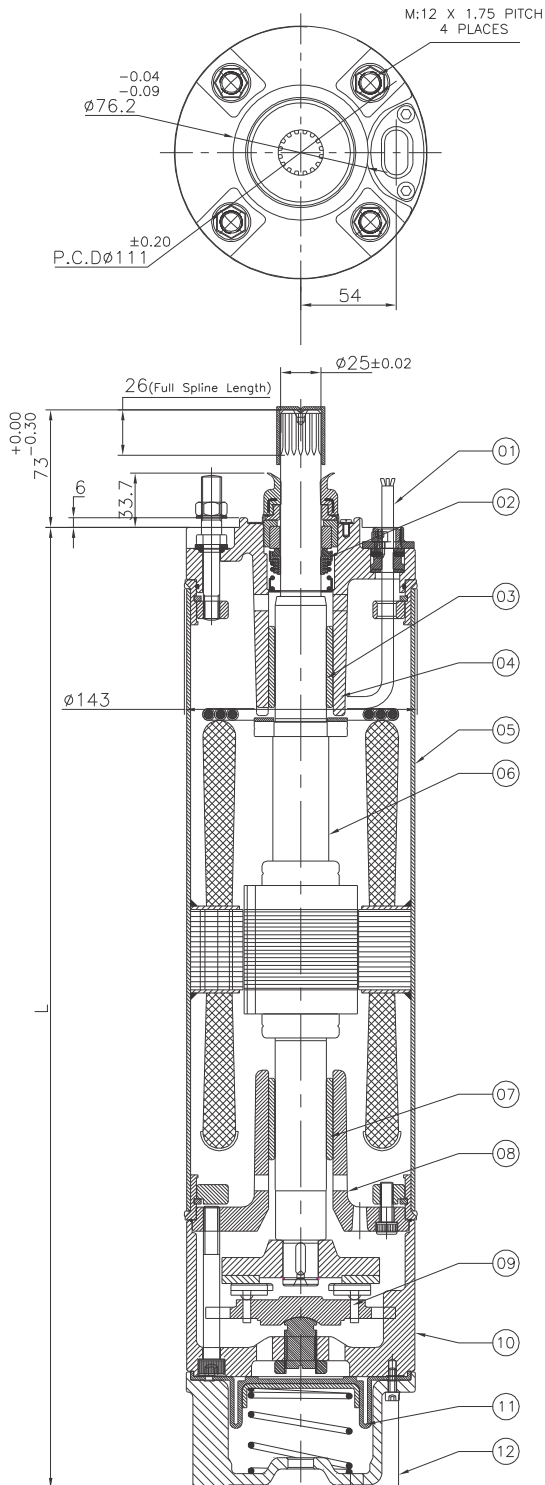

MOTOR-B

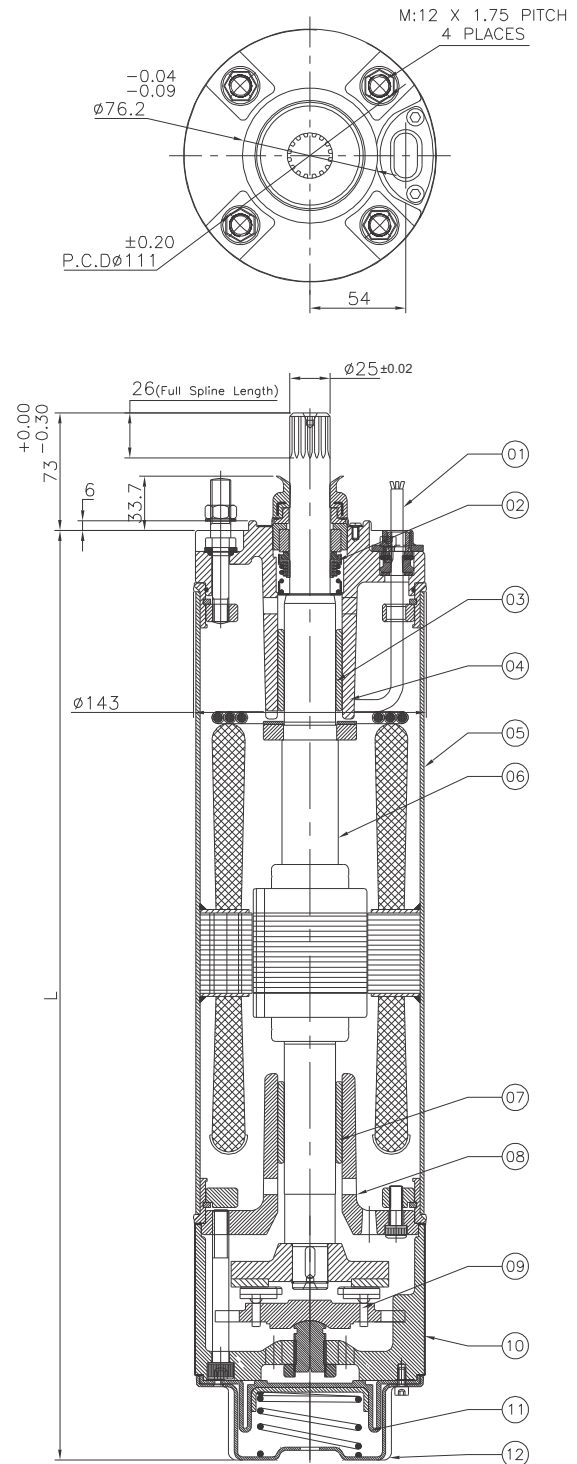

Submersible Motor

MOTOR-A		
SR NO.	PARTS NAME	MATERIAL
01	CABLE 3 CORE/4 CORE	EPR
02	MECH / SEAL	CERAMIC/CARBON
03	BEARING BUSH	CARBON
04	UPPER HOUSING	CAST IRON (F.G 200)
05	MOTOR SHELL	S.S.304
06	ROTOR SHAFT	S.S.431
07	BEARING BUSH	CARBON
08	LOWER HOUSING	CAST IRON (F.G 200)
09	THRUST BEARING SET	CARBON / S.S.420
10	LOWER PART-2	CAST IRON (F.G 200)
11	PRESSURE CUP	H.B.R
12	MOTOR BASE	CAST IRON (F.G 200)
13	ALL HARDWARE	S.S.304

MOTOR-B		
SR NO.	PART'S NAME	MATERIAL
01	CABLE 3 CORE/4 CORE	EPR
02	MECH. SEAL	CERAMIC/CARBON
03	BEARING BUSH	CARBON
04	UPPER HOUSING	S.S.304 / CAST IRON WITH CLADED
05	MOTOR SHELL	S.S.304
06	ROTOR SHAFT	S.S.431
07	BEARING BUSH	CARBON
08	LOWER HOUSING	CAST IRON (F.G 200)
09	THRUST BEARING SET	CARBON / S.S.420
10	LOWER PART-2	CAST IRON WITH CLADED
11	PRESSURE CUP	H.B.R
12	MOTOR BASE	S.S.304
13	ALL HARDWARE	S.S.304

P _N		PW L [mm]	PW L [mm]	MOTOR WEIGHT [kg]		MOTOR WEIGHT (incl.pkg) [kg]	
[kW]	[HP]	C.I.	S.S.	S.S. 304	Cast Iron	S.S. 304	Cast Iron
2.2	3.00	657	637	24.0	20.0	27.0	24.0
3.7	5.00	667	647	39.0	35.0	42.7	39.4
4.1	5.50	682	662	43.0	39.0	46.7	43.4
5.5	7.50	747	727	46.0	49.0	51.2	54.2
7.5	10.00	777	757	50.0	54.0	54.2	57.8
9.3	12.50	803	787	53.0	59.0	56.8	63.0
11.0	15.00	847	827	61.0	63.0	64.8	66.6
13.0	17.50	897	877	64.0	67.0	67.7	70.7
15.0	20.00	937	917	70.0	71.0	74.6	75.2
18.5	25.00	992	972	76.0	80.0	79.8	83.5
22.0	30.00	1067	1047	90.0	90.0	94.2	94.3
26.0	35.00	1127	1107	94.0	97.0	98.0	101.0
30.0	40.00	1247	1227	102.0	100.0	108.0	105.0
37.0	50.00	1347	1347	127.5	125.5	133.5	130.5

6" T-TYPE REWINDABLE MOTOR

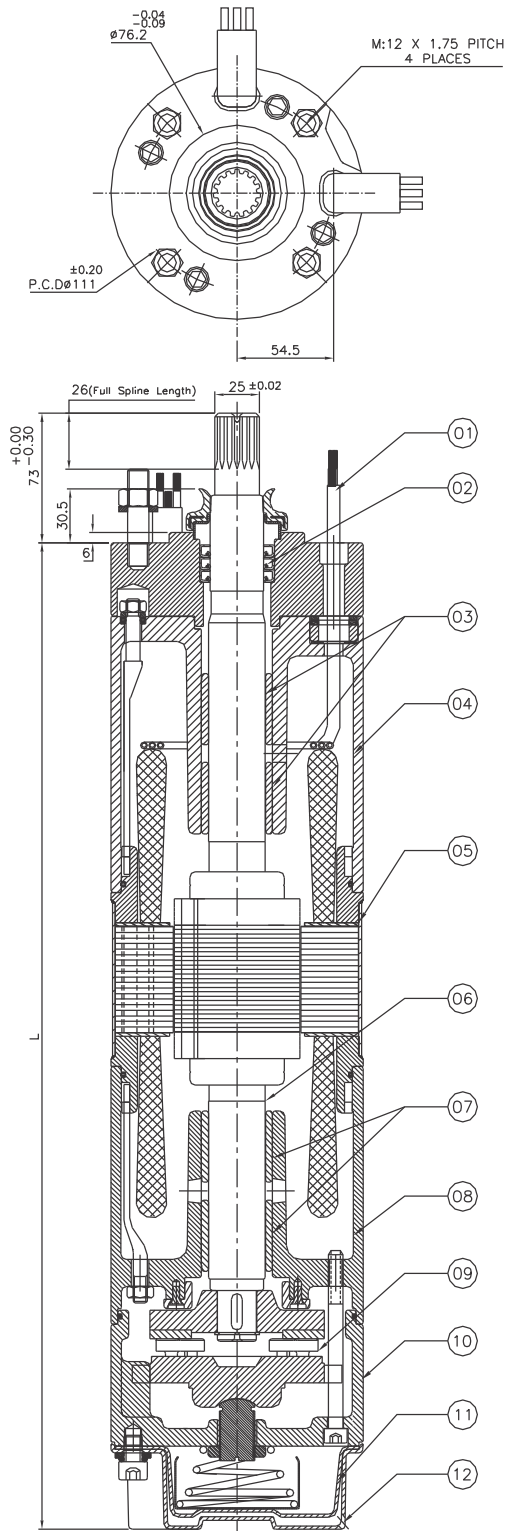

SR NO.	PARTS NAME	MATERIAL
01	CABLE 3 CORE/4 CORE	E.P.R
02	OIL SEAL	N.B.R
03	BEARING BUSH	CARBON
04	UPPER HOUSING	CAST IRON (F.G 200)
05	MOTOR SHELL	S.S.304
06	ROTOR SHAFT	S.S.431
07	BEARING BUSH	CARBON
08	LOWER HOUSING	CAST IRON (F.G 200)
09	THRUST BEARING SET	CARBON / S.S.420
10	LOWER PART-2	CAST IRON (F.G 200) WITH S.S. CLADED
11	PRESSURE CUP	H.B.R
12	MOTOR BASE	S.S.304
13	ALL HARDWARE	S.S.304

P _N		PW L [mm] C.I.	MOTOR WEIGHT	
[kW]	[HP]		[kg]	(incl.pkg) [kg]
2.20	3.00	590	20.0	24.0
2.94	4.00	590	20.0	24.0
3.70	5.00	605	35.0	39.4
3.70	5.00	615	39.0	43.4
4.40	6.00	630	44.0	49.5
5.50	7.50	695	49.0	54.6
7.50	10.00	725	54.0	58.2
9.30	12.50	755	59.0	63.0
11.0	15.00	795	62.0	66.0
13.0	17.50	845	67.0	70.7
15.0	20.0	885	70.0	74.2
18.5	25.00	940	76.0	80.2
22.0	30.00	1015	85.0	89.2
26.0	35.00	1075	97.0	101.0
30.0	40.00	1195	104.0	108.4
37.0	50.00	1295	113.0	117.8

Submersible Motor

6" T-TYPE REWINDABLE MOTOR (3.0 TO 30.0 H.P)

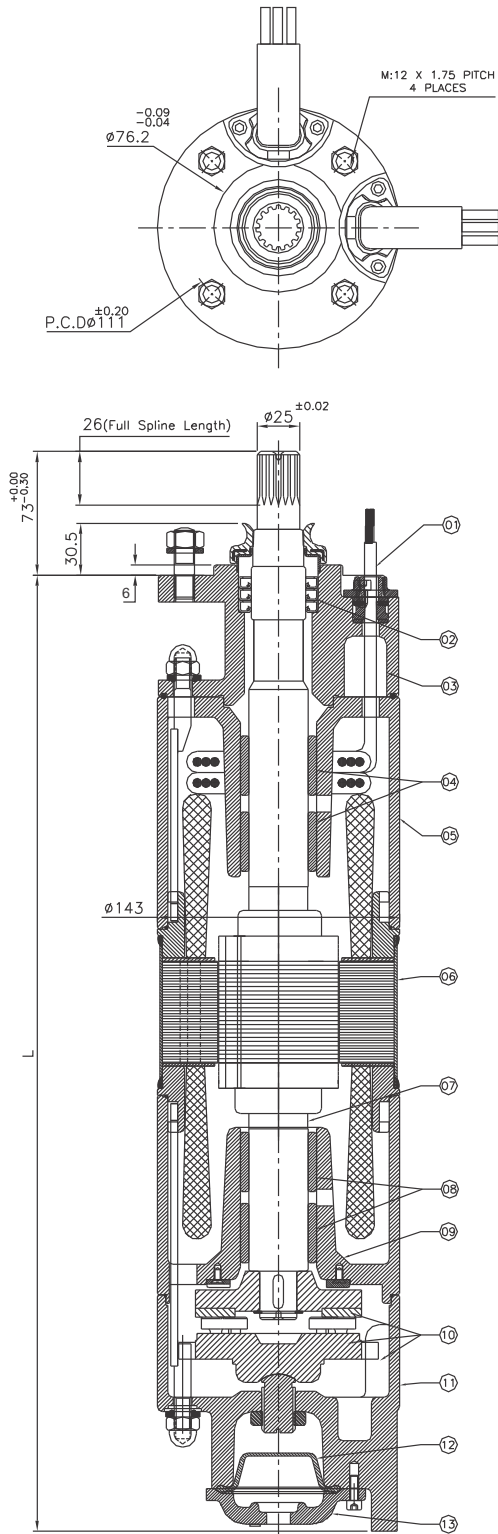

SR NO.	PARTS NAME	MATERIAL
01	CABLE 3 CORE/4 CORE	EPR
02	OIL SEAL	N.B.R
03	ADEPTOR	CAST IRON (F.G 200)
04	BEARING BUSH	CARBON
05	UPPER HOUSING	CAST IRON (F.G 200)
06	MOTOR SHELL	S.S.304
07	ROTOR SHAFT	S.S.431
08	BEARING BUSH	CARBON
09	LOWER HOUSING	CAST IRON (F.G 200)
10	THRUST BEARING SET	CARBON / S.S.420
11	MOTOR BASE	CAST IRON (F.G 200)
12	PRESSURE CUP	H.B.R
13	ALL HARDWARE	S.S.304

P _N		PW L [mm] C.I.	MOTOR WEIGHT	MOTOR WEIGHT
[kW]	[HP]		[kg]	(incl.pkg) [kg]
			Cast Iron	Cast Iron
2.20	3.00	600	32.0	36.0
3.70	5.00	615	36.0	40.0
4.40	6.00	640	40.0	44.0
5.50	7.50	655	43.0	47.0
7.50	10.00	705	49.0	53.0
9.30	12.50	735	56.0	60.0
11.0	15.00	765	60.0	64.0
13.0	17.50	805	63.0	67.0
15.0	20.00	855	69.0	73.0
18.5	25.00	895	73.0	77.0
22.0	30.00	950	88.0	92.0

6" PRIME REWINDABLE MOTOR

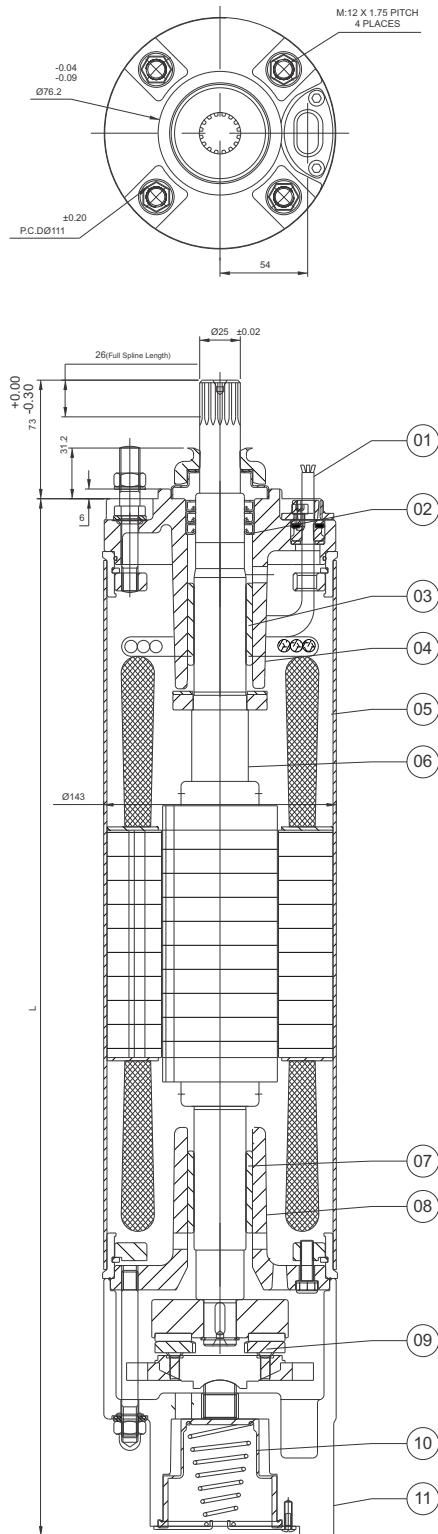

SR NO.	PARTS NAME	MATERIAL
01	CABLE 3 CORE/4 CORE	EPR
02	OIL SEAL	N.B.R
03	BEARING BUSH	CARBON
04	UPPER HOUSING	CAST IRON (F.G 200)
05	MOTOR SHELL	S.S.304
06	ROTOR SHAFT	S.S.431
07	BEARING BUSH	CARBON
08	LOWER HOUSING	CAST IRON (F.G 200)
09	THRUST BEARING SET	CARBON / S.S.420
10	PRESSURE CUP	H.B.R
11	MOTOR BASE	CAST IRON (F.G 200)
12	ALL HARDWARE	S.S.304

P_N		PW L [mm] C.I.	MOTOR WEIGHT [kg]	MOTOR WEIGHT (incl.pkg) [kg]
[kW]	[HP]			
2.2	3.00	657	38.0	42.0
3.7	5.00	667	38.7	42.5
4.5	6.00	682	39.5	43.5
5.5	7.50	747	42.0	46.5
7.5	10.00	777	47.0	50.5
9.3	12.50	803	49.3	53.6
11.0	15.00	847	50.0	55.5
13.0	17.50	897	56.4	61.0
15.0	20.00	937	62.5	67.5
18.5	25.00	992	64.4	69.0

Submersible Motor

Technical Data of 6" Motors / 50 Hz

PN		Thrust F [N]	UN [V]	nN [min-1]	IN [A]	IA [A]	η (Eff.) [%] at % load			cos κ (PF) at % load			TN [Nm]	TA [Nm]
[H.P.]	[kW]						50	75	100	50	75	100		
3.00	2.2						15500	380	2845	6.21	21.7	62		
		400	2875	6.30	22.2	61		63	65	0.64	0.70	0.71	7.30	11.78
		415	2875	6.51	23.1	59		66	67	0.61	0.69	0.71	7.30	12.66
5.50	4	15500	380	2915	10.39	47	71	74	76	0.60	0.71	0.77	13.11	15.50
			400	2935	10.61	50	69	73	76	0.54	0.66	0.74	13.11	17.31
			415	2935	10.90	52	66	72	76	0.50	0.60	0.70	13.00	18.82
7.50	5.5	15500	380	2865	13.71	47	73	76	76	0.68	0.79	0.83	18.31	15.40
			400	2885	13.30	50	72	76	76	0.62	0.75	0.81	18.20	17.30
			415	2890	13.41	54	72	75	75	0.60	0.71	0.79	18.10	18.70
10.0	7.5	15500	380	2870	18.29	58	77	78	78	0.70	0.80	0.83	25.10	19.20
			400	2890	17.70	63	76	78	78	0.66	0.75	0.81	24.80	21.40
			415	2890	17.70	64	73	74	77	0.62	0.74	0.81	24.80	23.40
12.5	9.3	15500	380	2855	22.00	75	79	80	79	0.70	0.80	0.83	31.11	25.91
			400	2860	21.30	77	79	79	78	0.63	0.75	0.81	31.00	29.00
			415	2885	21.10	81	77	79	78	0.60	0.72	0.82	30.91	31.42
15.0	11	15500	380	2865	25.79	93	77	80	78	0.71	0.80	0.84	36.60	31.50
			400	2880	25.21	97	77	80	80	0.66	0.75	0.83	36.40	35.30
			415	2890	25.10	101	75	78	80	0.61	0.73	0.81	36.30	38.10
17.5	13	15500	380	2885	30.11	117	79	81	80	0.69	0.79	0.83	43.20	45.00
			400	2900	29.60	126	78	80	81	0.62	0.75	0.80	42.70	50.20
			415	2905	29.71	131	77	79	81	0.58	0.70	0.77	42.60	54.50
20.0	15	15500	380	2880	33.91	140	80	82	81	0.72	0.82	0.85	49.71	53.80
			400	2895	33.10	147	80	81	81	0.66	0.78	0.84	49.40	60.30
			415	2900	33.00	155	78	80	81	0.61	0.74	0.82	49.20	65.40
25.0	18.5	15500	380	2870	42.31	171	80	82	81	0.68	0.79	0.84	61.72	75.21
			400	2880	42.00	182	77	80	81	0.61	0.73	0.81	61.22	84.30
			415	2895	42.49	188	76	80	80	0.58	0.71	0.78	61.00	91.20
30.0	22	15500	380	2875	49.11	217	82	83	84	0.69	0.78	0.83	72.62	91.10
			400	2900	49.00	231	80	82	83	0.61	0.74	0.81	72.48	102.10
			415	2910	49.59	239	76	81	82	0.57	0.68	0.78	72.20	110.60
35.0	26	15500	380	2890	57.49	267	82	84	83	0.69	0.79	0.85	86.10	120.40
			400	2905	56.72	283	81	82	83	0.60	0.74	0.84	85.50	134.80
			415	2910	57.30	295	77	83	83	0.56	0.70	0.81	85.20	146.20
40.0	30	27500	380	2895	66.39	329	81	84	83	0.68	0.77	0.84	98.82	135.00
			400	2910	66.42	346	80	82	82	0.61	0.74	0.81	98.41	151.00
			415	2910	67.50	360	77	81	82	0.56	0.69	0.78	98.22	164.00
50.0	37	27500	380	2890	82.00	406	82	83	83	0.68	0.79	0.83	122.00	192.70
			400	2910	81.92	432	81	82	83	0.60	0.73	0.81	121.50	215.70
			415	2910	83.91	449	78	80	82	0.56	0.67	0.77	121.20	234.10

- PN - Rated Output
- UN - Rated Voltage
- nN - RPM
- IN - Full Load Current
- IA - Starting Current
- η - Motor Efficiency
- cosκ - Power Factor
- TN - Full Load Torque
- TA - Starting Torque
- F[N] - Axial Thrust Load

Technical Data of 6" Motors / 60 Hz

PN		P _{MAX} [kW]	Thrust Load [N]	U _N [V]	n _N [min-1]	I _N [A]	I _A [A]	τ (Eff.) [%] at % load			cos κ (PF) at % load			T _N [Nm]	T _A [Nm]
[H.P.]	[kW]							50	75	100	50	75	100		
3.00	2.2	2.5	15500	230	3520	10	40	70	73	76	0.51	0.62	0.72	6.64	9.8
				380	3530	6.51	33	66	71	76	0.50	0.61	0.70	5.97	8.00
				460	3520	5.59	28	70	75	77	0.55	0.65	0.74	6.64	8.13
5.50	4	4.6	15500	230	3520	26.11	105	71	75	77	0.53	0.64	0.73	12.49	18.6
				380	3530	13.30	62	67	72	77	0.51	0.64	0.71	12.41	15.1
				460	3520	10.11	51	71	76	78	0.56	0.68	0.75	12.48	15.3
7.50	5.5	6.3	15500	230	3490	26.11	106	74	78	78	0.62	0.73	0.80	17.29	15.9
				380	3480	15.39	62	75	78	78	0.65	0.75	0.81	17.29	15.0
				460	3480	12.90	51	75	77	77	0.66	0.76	0.82	17.29	15.1
10.0	7.5	8.6	15500	230	3490	35.91	145	75	78	79	0.59	0.71	0.78	23.58	22.41
				380	3485	20.79	81	76	78	79	0.65	0.75	0.81	23.58	20.20
				460	3470	17.20	65	76	78	78	0.67	0.78	0.82	23.70	19.40
12.5	9.3	10.7	15500	230	3490	44.41	183	76	79	79	0.60	0.71	0.78	29.3	28.91
				380	3470	25.60	101	77	79	80	0.65	0.75	0.81	29.4	25.89
				460	3460	20.79	78	79	80	80	0.67	0.78	0.82	29.4	24.40
15.0	11	12.7	15500	230	3480	51.21	221	77	80	81	0.61	0.72	0.80	34.59	35.61
				380	3490	30.29	129	77	81	81	0.62	0.74	0.80	34.51	34.30
				460	3480	25.00	97	78	81	80	0.69	0.77	0.83	34.70	31.50
17.5	13	15.0	15500	230	3500	62.39	289	76	80	82	0.56	0.68	0.76	40.71	50.51
				380	3505	36.30	164	77	81	82	0.59	0.71	0.79	40.71	47.21
				460	3490	29.00	124	77	81	81	0.66	0.76	0.82	40.90	43.30
20.0	15	17.3	15500	230	3500	65.89	324	80	82	83	0.64	0.74	0.81	47.1	59.52
				380	3490	39.10	188	81	83	83	0.66	0.77	0.83	47.2	56.50
				460	3495	32.11	150	80	83	83	0.69	0.78	0.84	47.1	55.61
25.0	18.5	21.3	15500	230	3490	85.39	401	77	81	82	0.60	0.71	0.77	58.11	81.81
				380	3490	52.49	249	77	81	81	0.59	0.70	0.77	58.11	83.60
				460	3480	40.60	183	80	82	82	0.65	0.76	0.81	58.39	74.51
30.0	22	25.3	15500	230	3510	100.2	521	81	84	84	0.66	0.74	0.77	68.78	96.61
				380	3510	59.89	390	82	83	84	0.67	0.76	0.78	68.78	94.91
				460	3500	47.11	231	83	84	84	0.72	0.79	0.81	69.10	85.80
35.0	26	29.9	15500	230	3510	118.3	658	83	84	85	0.63	0.72	0.76	81.29	135.00
				380	3500	67.49	360	83	85	85	0.63	0.74	0.81	81.61	121.41
				460	3510	55.71	288	83	85	85	0.64	0.75	0.84	81.6	117.20
40.0	30	34.5	27500	230	3510	135.7	757	78	81	83	0.59	0.71	0.78	93.81	139.61
				380	3510	79.59	436	79	83	84	0.62	0.75	0.81	93.89	132.90
				460	3500	64.41	345	81	83	84	0.63	0.76	0.82	94.00	126.41
50.0	37.0	42.6	27500	230	3510	135.6	757	78	82	83	0.59	0.71	0.78	93.78	139.61
				380	3510	102.7	568	77	81	82	0.59	0.72	0.78	115.8	193.61
				460	3500	79.12	430	81	84	85	0.63	0.75	0.82	115.9	177.80

- PN - Rated Output
- UN - Rated Voltage
- nN - RPM
- IN - Full Load Current
- IA - Starting Current
- τ - Motor Efficiency
- cosκ - Power Factor
- TN - Full Load Torque
- TA - Starting Torque
- F[N] - Axial Thrust Load

Submersible Motor

Technical Data of 6" Prime Motors / 50Hz

P _N		Thrust F [N]	U _N [V]	n _N [min ⁻¹]	I _N [A]	I _A [A]	η(Eff.) [%] at % load			COS φ(PF) At % load			T _N [Nm]	T _A [Nm]
[HP]	[kW]						50	75	100	50	75	100		
3.00	2.2						15500	380	2850	5.80	21.5	62		
		400	2875	6.00	22.0	61		63	66	0.64	0.70	0.71	7.30	11.80
		415	2880	6.20	23.0	60		66	67	0.61	0.69	0.72	7.30	12.70
5.50	4	15500	380	2920	10.00	47	71	74	76	0.60	0.71	0.77	13.10	15.55
			400	2935	10.20	50	69	73	76	0.55	0.66	0.74	13.10	17.32
			415	2935	10.50	51	66	73	76	0.50	0.60	0.71	13.00	18.84
7.50	5.5	15500	380	2865	13.10	46	73	76	76	0.68	0.79	0.83	18.31	15.45
			400	2885	12.80	51	72	76	76	0.62	0.76	0.81	18.20	17.32
			415	2892	12.60	54	72	75	75	0.60	0.72	0.79	18.10	18.74
10.0	7.5	15500	380	2872	17.80	59	77	78	78	0.70	0.80	0.83	25.10	19.40
			400	2890	17.20	63	76	78	78	0.66	0.74	0.81	24.80	21.50
			415	2890	17.10	64	73	74	77	0.62	0.74	0.81	24.80	23.50
12.5	9.3	15500	380	2860	21.50	75	79	80	79	0.70	0.80	0.83	31.10	25.95
			400	2870	21.00	77	79	79	78	0.63	0.75	0.81	31.00	29.10
			415	2885	20.80	80	77	79	78	0.60	0.72	0.82	30.90	31.45
15.0	11	15500	380	2870	25.20	93	77	80	80	0.71	0.80	0.85	36.60	31.80
			400	2880	25.00	97	77	80	80	0.66	0.75	0.83	36.40	35.30
			415	2890	24.80	100	75	78	80	0.61	0.73	0.81	36.30	38.20
17.5	13	15500	380	2885	29.80	117	79	81	80	0.69	0.79	0.83	43.10	45.10
			400	2900	29.20	126	78	80	81	0.62	0.75	0.80	42.70	50.25
			415	2900	29.00	132	77	79	81	0.58	0.71	0.77	42.60	54.50
20.0	15	15500	380	2880	33.10	140	80	81	81	0.72	0.82	0.85	49.70	53.90
			400	2895	32.50	146	80	81	81	0.66	0.79	0.84	49.40	60.30
			415	2900	32.30	154	78	80	81	0.61	0.74	0.82	49.20	65.50
25.0	18.5	15500	380	2870	42.00	170	80	82	81	0.68	0.79	0.84	61.70	75.25
			400	2880	41.50	182	77	80	81	0.61	0.73	0.81	61.22	84.35
			415	2895	42.20	188	76	80	80	0.58	0.71	0.79	61.00	91.30

- P_N - Rated Output
- U_N - Rated Voltage
- n_N - RPM
- I_N - Full Load Current
- I_A - Starting Current
- η - Motor Efficiency
- cosφ - Power Factor
- T_N - Full Load Torque
- T_A - Starting Torque
- F[N] - Axial Thrust Load

Exploded Drawing of 6" Motor-A

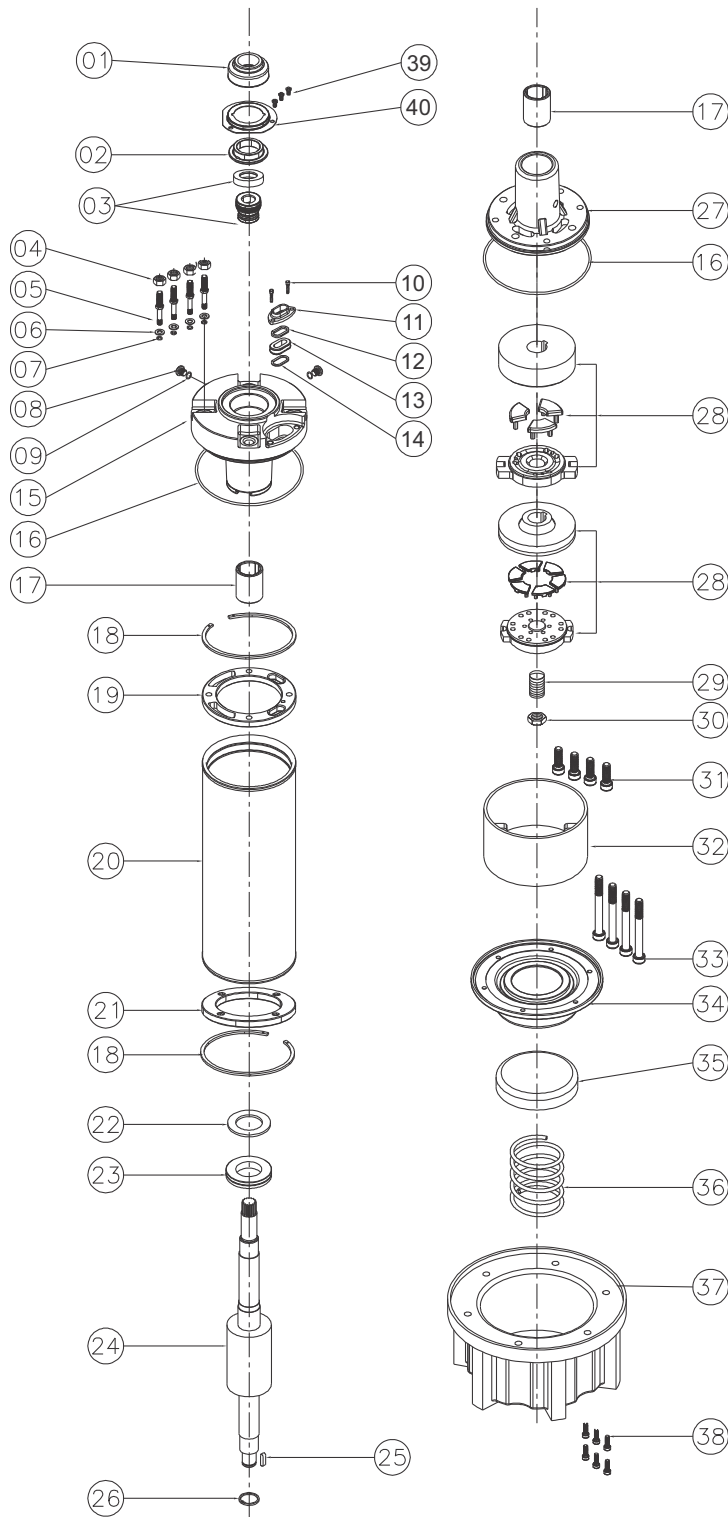

No.	PARTS NAME
1	SAND GUARD
2	UPPER COLLER
3	MECH.SEAL
4	NUT
5	STUD
6	STUD WASHER
7	STUD "O" RING
8	DRAIN PLUG
9	DRAIN PLUG "O" RING
10	ALLEN BOLT
11	CABLE PROTECTOR CAP
12	PLASTIC GROMMET WASHER
13	RUBBER GROMMET
14	S.S. GROMMET WASHER
15	UPPER HOUSING
16	'O' RING(UPPER & LOWER)
17	BEARING BUSH
18	CIR CLIP
19	UPPER FLANGE
20	STATOR BODY
21	LOWER FLANGE
22	TEFLON WASHER
23	THRUST RING
24	ROTOR SHAFT
25	ROTOR KEY
26	CIR CLIP BEARING SIDE
27	LOWER HOUSING
28	THRUST BEARING SET (UP TO 10.0 H.P)
28	THRUST BEARING SET (ABOVE 10.0 H.P)
29	ROCKER
30	ROCKER LOCK NUT
31	ALLEN BOLT LOWER SIDE
32	LOWER PART-2
33	ALLEN BOLT LOWER PART-2 SIDE
34	PRESSURE CUP
35	SPRING JACKET
36	SPRING
37	MOTOR BASE
38	ALLEN BOLT MOTOR BASE SIDE
39	UPPER CAP
40	UPPER CAP SCREW

Submersible Motor

Exploded Drawing of 6" Motor-B

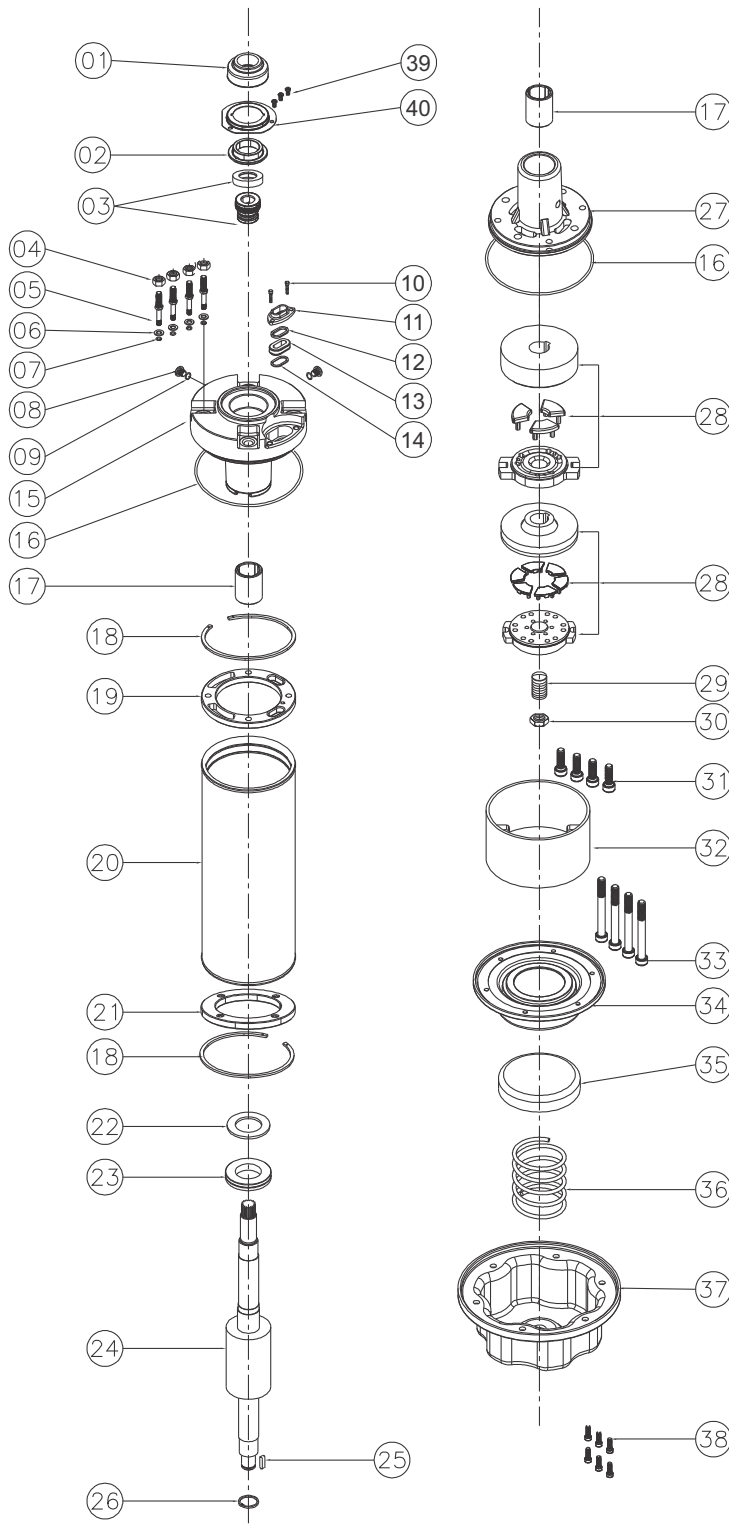

No.	PARTS NAME
1	SAND GUARD
2	UPPER COLLER
3	MECH.SEAL
4	NUT
5	STUD
6	STUD WASHER
7	STUD "O" RING
8	DRAIN PLUG
9	DRAIN PLUG "O" RING
10	ALLEN BOLT
11	CABLE PROTECTOR CAP
12	PLASTIC GROMMET WASHER
13	RUBBER GROMMET
14	S.S. GROMMET WASHER
15	UPPER HOUSING
16	'O' RING(UPPER & LOWER)
17	BEARING BUSH
18	CIR CLIP
19	UPPER FLANGE
20	STATOR BODY
21	LOWER FLANGE
22	TEFLON WASHER
23	THRUST RING
24	ROTOR SHAFT
25	ROTOR KEY
26	CIR CLIP BEARING SIDE
27	LOWER HOUSING
28	THRUST BEARING SET (UP TO 10.0 H.P)
	THRUST BEARING SET (ABOVE 10.0 H.P)
29	ROCKER
30	ROCKER LOCK NUT
31	ALLEN BOLT LOWER SIDE
32	LOWER PART-2
33	ALLEN BOLT LOWER PART-2 SIDE
34	PRESSURE CUP
35	SPRING JACKET
36	SPRING
37	MOTOR BASE
38	ALLEN BOLT MOTOR BASE SIDE
39	UPPER CAP
40	UPPER CAP SCREW

Exploded Drawing of 6" T-Type Motor

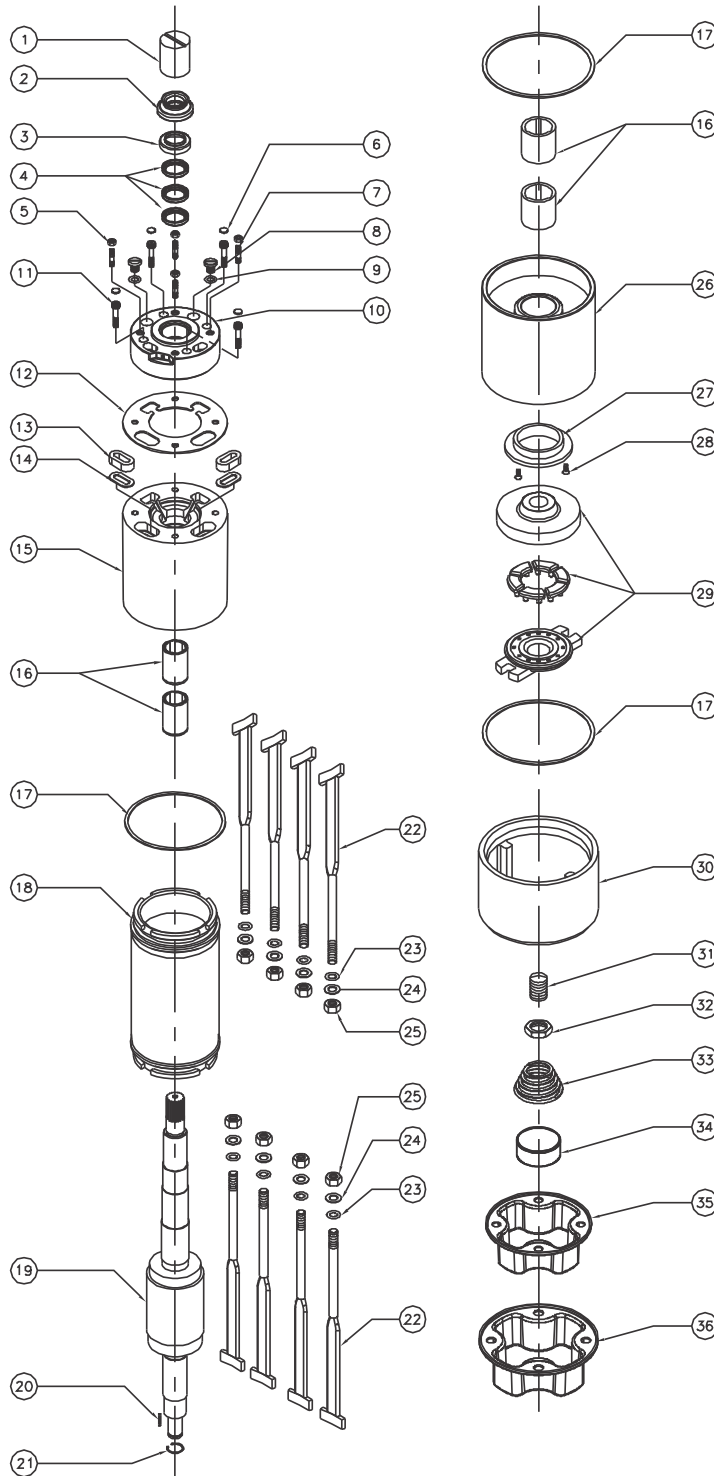

NO.	PARTS NAME
1.	ROTOR CAP
2.	SAND GUARD
3.	UPPER CAP
4.	OIL SEAL
5.	HEX. NUT (UPPER SIDE)
6.	ALLEN BOLT CAP
7.	STUD (UPPER SIDE)
8.	DRAIN PLUG
9.	DRAIN PLUG 'O' RING
10.	ADAPTOR
11.	ALLEN BOLT
12.	PAPER GASKET
13.	CABLE GROMMET
14.	CABLE GROMMET WASHER
15.	UPPER HOUSING
16.	BEARING BUSH
17.	PAPER GASKET
18.	STATOR BODY
19.	ROTOR
20.	ROTOR KEY
21.	CIRCLIP
22.	T-BOLT
23.	T-BOLT 'O' RING
24.	WASHER
25.	HEX NUT
26.	LOWER HOUSING
27.	C.T. BEARING
28.	SCREW
29.	THRUST BEARING SET
30.	LOWER PART-2
31.	ROCKER
32.	ROCKER LOCK NUT
33.	SPRING
34.	SPRING JACKET
35.	PRESSURE CUP
36.	MOTOR BASE

Submersible Motor

Exploded Drawing of 6" T-Type Motor (3.0 to 30.0 H.P)

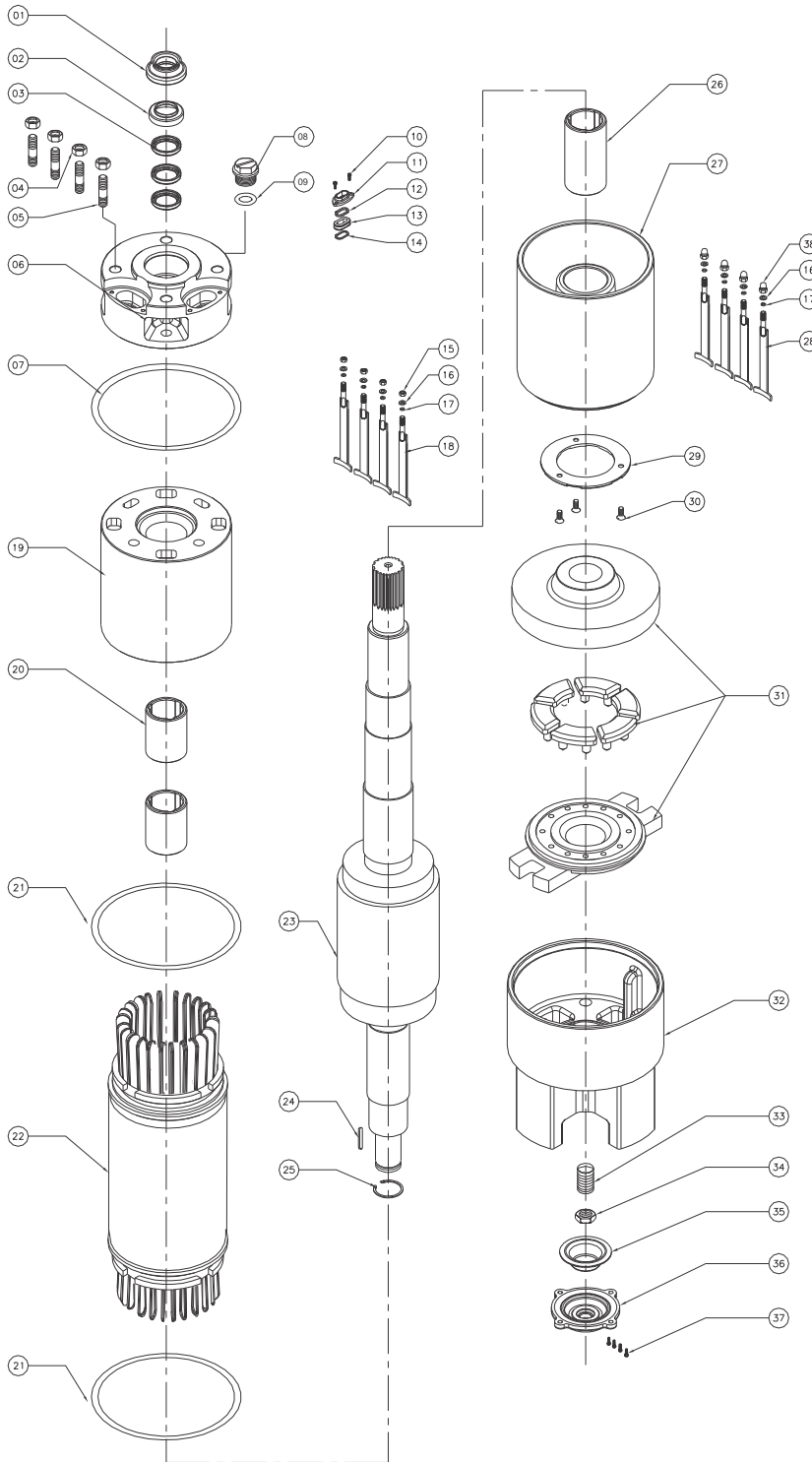

NO.	PARTS NAME
1.	SAND GUARD
2.	UPPER CAP
3.	OIL SEAL
4.	HEX NUT
5.	UPPER STUD
6.	ADOPTER
7.	ADOPTER 'O' RING
8.	DRAIN PLUG
9.	DRAIN PLUG 'O' RING
10.	ALLEN BOLT
11.	CABLE PROTECTOR CAP
12.	PLASTIC GROMMET WASHER
13.	CABLE GROMMET
14.	S.S GROMMET WASHER
15.	HEX NUT
16.	WASHER
17.	O'RING
18.	UPPER T-BOLT
19.	UPPER HOUSING
20.	BEARING BUSH
21.	RUBBER 'O' RING
22.	STATOR BODY
23.	ROTOR FINISH
24.	ROTOR KEY
25.	CIR CLIP
26.	BEARING BUSH
27.	LOWER HOUSING
28.	LOWER T-BOLT
29.	C.T BEARING
30.	SCREW
31.	THRUST BEARING
32.	MOTOR BASE
33.	ROCKER
34.	ROCKER LOCK NUT
35.	PRESSURE CUP
36.	MOTOR BASE PLATE
37.	ALLEN BOLT
38.	DOME NUT

Exploded Drawing of 6" Prime Motor

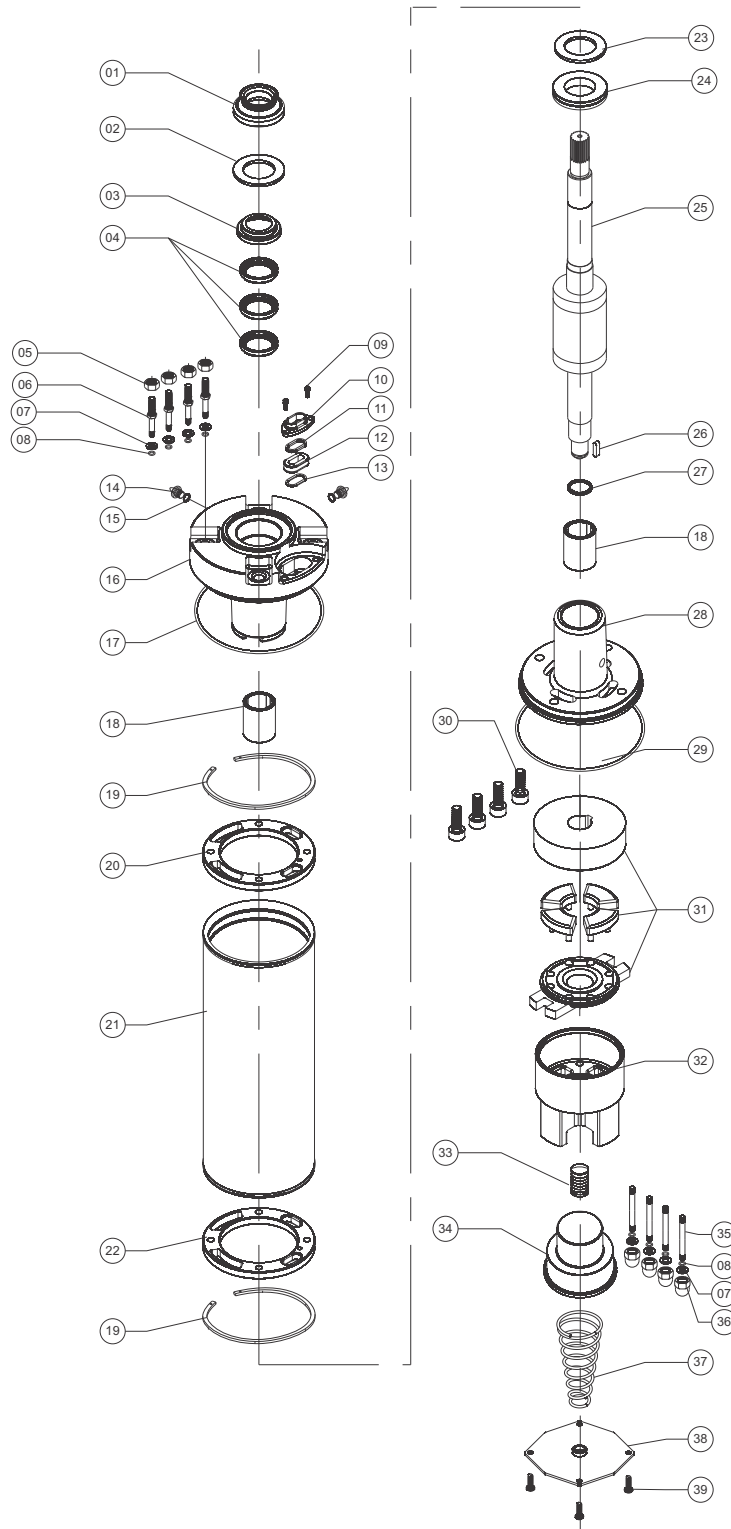

No.	PARTS NAME
1	SAND GUARD
2	TEFLON WASHER
3	UPPER CAP
4	OIL SEAL
5	HEX NUT
6	STUD
7	STUD WASHER
8	STUD "O" RING
9	ALLEN BOLT
10	CABLE PROTECTOR CAP
11	PLASTIC GROMMET WASHER
12	RUBBER GROMMET
13	S.S. GROMMET WASHER
14	DRAIN PLUG
15	'O' RING(DRAIN PLUG)
16	UPPER HOUSING
17	'O' RING
18	BEARING BUSH
19	CIRCLIP
20	UPPER FLANGE
21	STATOR BODY
22	LOWER FLANGE
23	TEFLON WASHER
24	THRUST RING
25	ROTOR FINISH
26	KEY
27	CIRCLIP
28	LOWER HOUSING
29	'O' RING
30	ALLEN BOLT
31	THRUST BEARING SET
32	MOTOR BASE
33	ROCKER
34	PRESSURE CUP
35	LOWER STUD
36	DOM NUT
37	SPRING
38	MOTOR BASE PLATE
39	SCREW

Submersible Motor

8" REWINDABLE MOTORS

TECHNICAL SPECIFICATIONS:

- 8" Water Lubricated Submersible Motors are rewindable.
- Coupling dimensions as per NEMA standard.
- Winding wire : Polywrapped / PVC winding available on specific demand
- Degree of protection : IP68.
- Max water temperature : 35°C.
- Starts per hour : 20 time (Max.).
- Allowable voltage variation : +6% - 10%.
- Motor shaft of Stainless steel.
- Stator shell of Stainless steel.
- Max depth immersion : 350 M.
- Mounting : vertical / horizontal.
- Motor Cable length : 3 Meter / 3 Core with separate earth cable & 4 Core.
- Cooling Flow : V:0.2 M/S.
- Coolant : Clear Water.

VERSIONS:

Three Phase : 22 kW To 55 kW / 380-415 Volt /50 Hz

30 kW To 55 kW/ 380-460 Volt /60 Hz.

Motor With Other Voltage and frequency ratings are available on specific Demand.

8" REWINDABLE MOTOR

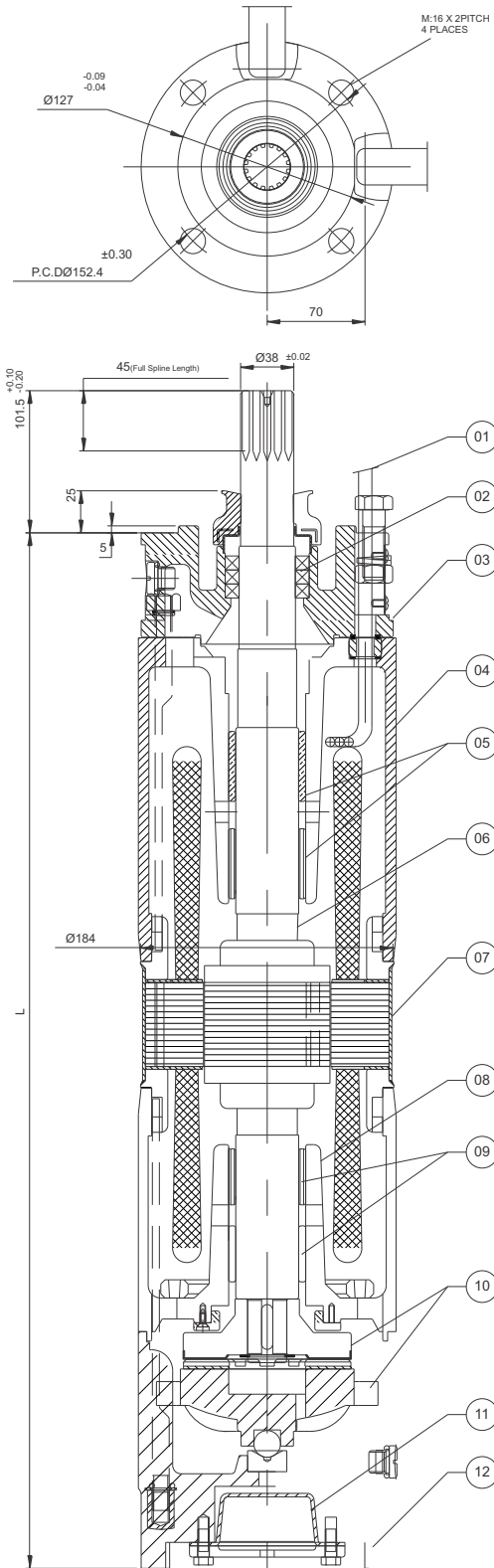

SR NO.	PARTS NAME	MATERIAL
01	CABLE 3 CORE/4 CORE	EPR
02	OIL SEAL	N.B.R
03	ADAPTOR	CAST IRON(FG-200)
04	UPPER HOUSING	CAST IRON(FG-200)
05	BEARING BUSH	LTB-4 (2% Ni.) / M.S-N.B.R
06	ROTOR SHAFT	S.S.431
07	MOTOR SHELL	S.S.304
08	LOWER HOUSING	CAST IRON(FG-200)
09	BEARING BUSH	LTB-4 (2% Ni.) / M.S-N.B.R
10	THRUST BEARING SET	CARBON / S.S.420
11	PRESSURE CUP	H.B.R
12	MOTOR BASE	CAST IRON(FG-200)
13	ALL HARDWARE	S.S.304

P _N		PW L [mm] C.I.	MOTOR WEIGHT [kg]	MOTOR WEIGHT (incl.pkg) [kg]
[kW]	[HP]		Cast Iron	Cast Iron
30.0	40.00	1250.00	121	137.4
37.0	50.00	1320.00	138	156.4
45.0	60.00	1320.00	165	183.4
55.0	75.00	1380.00	205	223

Submersible Motor

Technical Data of 8" Motors / 50 Hz

PN		Thrust Load [N]	UN [V]	nN [min-1]	IN [A]	IA [A]	τ (Eff.) [%] at % load			cos κ (PF) at % load			TN [Nm]	TA [Nm]
[H.P.]	[kW]						50	75	100	50	75	100		
40.0	30	45000	380	2885	63.10	301	83.4	84.4	83.2	0.88	0.88	0.89	99.1	126
			400	2900	60.00	317	83.5	85	84.4	0.80	0.85	0.89	99.0	141
			415	2910	58.00	331	83.4	85.1	84.8	0.76	0.88	0.89	98.1	150
50.0	37	45000	380	2890	79.11	377	84.5	85.2	84.0	0.81	0.85	0.87	122	155
			400	2910	76.00	400	83.8	85.2	84.5	0.75	0.82	0.86	122	176
			415	2910	75.10	411	82.5	84.4	84.3	0.70	0.80	0.85	120	189
60.0	45	45000	380	2895	92.90	490	85.7	86.5	85.2	0.80	0.85	0.88	149	218
			400	2910	90.00	520	85.3	86.5	86.0	0.75	0.82	0.86	148	240
			415	2910	88.00	542	84.4	86.1	85.8	0.69	0.80	0.85	147	262
75.0	55	45000	380	2910	115.0	625	86.4	86.8	85.7	0.78	0.84	0.88	182	302
			400	2915	110.0	660	85.8	87.0	86.5	0.72	0.82	0.85	180	341
			415	2920	109.0	687	84.7	86.5	86.2	0.67	0.78	0.85	180	367

Technical Data of 8" Motors / 60 Hz

PN		Thrust Load [N]	UN [V]	nN [min-1]	IN [A]	IA [A]	τ (Eff.) [%] at % load			cos κ (PF) at % load			TN [Nm]	TA [Nm]
[H.P.]	[kW]						50	75	100	50	75	100		
40.0	30	45000	380	3500	73	393	82.3	84.6	84.6	0.81	0.86	0.88	99	142
			460	3495	60	325	81.5	83.5	83.4	0.82	0.86	0.89	99	131
50.0	37	45000	380	3510	91	513	83.2	85.1	85.4	0.76	0.82	0.85	121	178
			460	3490	75	407	83.8	85.4	84.8	0.77	0.85	0.87	122	163
60.0	45	45000	380	3510	110	660	83.5	85.7	85.8	0.73	0.81	0.85	149	241
			460	3505	90	523	85.0	86.5	86.3	0.77	0.84	0.87	149	220
75.0	55	45000	380	3520	137	841	84.3	86.5	86.5	0.72	0.81	0.84	182	320
			460	3515	108	658	85.7	87.1	86.8	0.77	0.84	0.88	181	288

- PN - Rated Output
- F[N] - Axial Thrust Load
- UN - Rated Voltage
- nN - RPM
- IN - Full Load Current
- IA - Starting Current
- τ - Motor Efficiency
- cos κ - Power Factor
- TN - Full Load Torque
- TA - Starting Torque

Exploded Drawing of 8" Motor

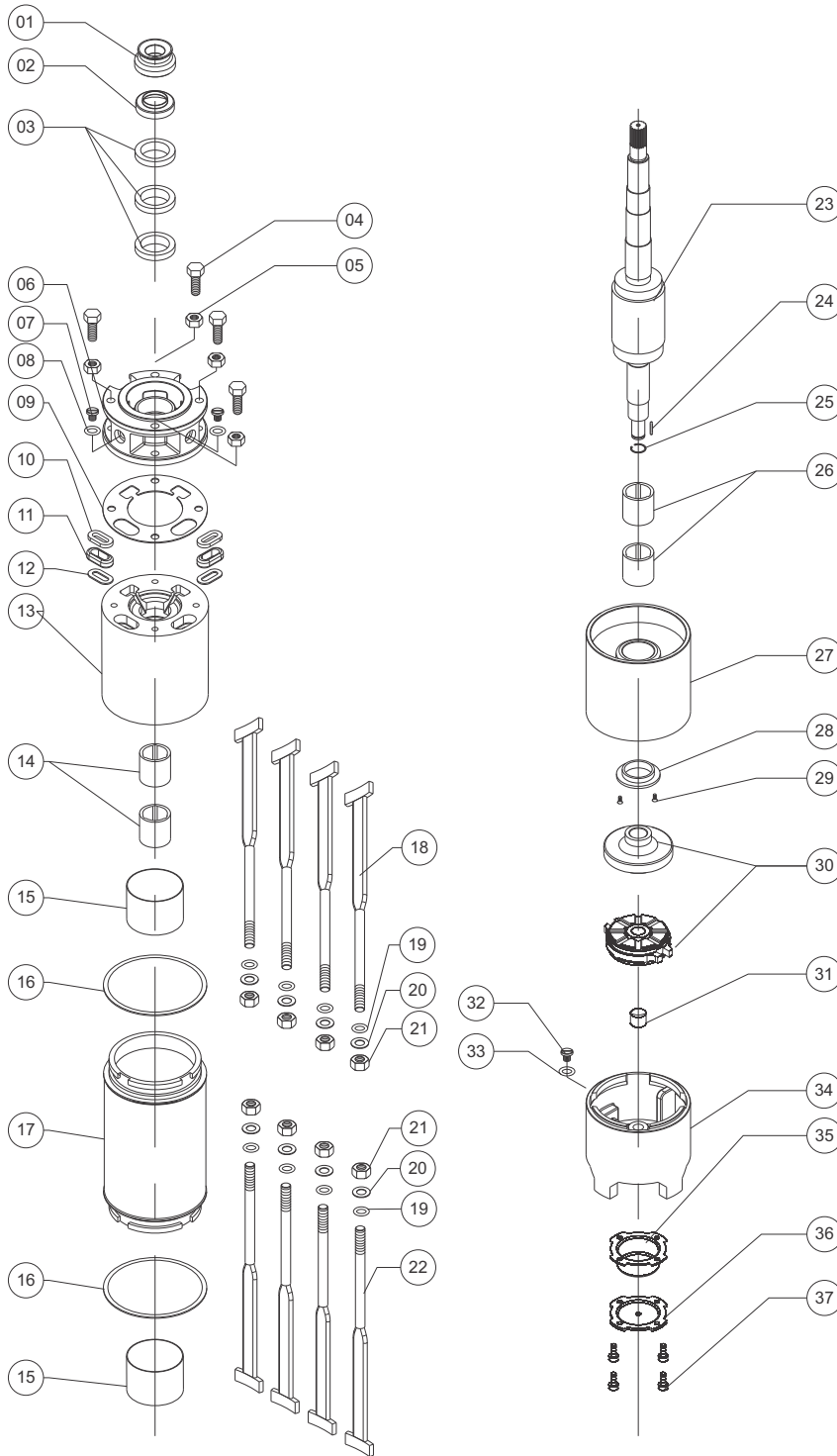

No.	PARTS NAME
1	SAND GUARD (M.S INSERT)
2	UPPER CAP
3	OIL SEAL
4	HEX BOLT
5	HEX NUT
6	ADAPTOR
7	DRAIN PLUG
8	DRAIN PLUG 'O' RING
9	PAPER GASKET
10	GROMMET WASHER
11	GROMMET
12	GROMMET WASHER
13	UPPER HOUSING
14	BEARING BUSH (UPPER SIDE)
15	WINDING CAP
16	PAPER GASKET
17	STATOR BODY
18	T-BOLT (UPPER SIDE)
19	T-BOLT 'O' RING
20	T-BOLT WASHER
21	HEX NUT
22	T-BOLT (LOWER SIDE)
23	ROTOR
24	ROTOR KEY
25	ROTOR CIR CLIP
26	BEARING BUSH (LOWER SIDE)
27	LOWER HOUSING
28	FIBER C.T BEARING
29	SCREW
30	COUNTER BEARING SET
31	FIX ROCKER
32	DRAIN PLUG
33	DRAIN PLUG 'O' RING
34	MOTOR BASE
35	PRESSURE CUP
36	MOTOR BASE PLATE
37	HEX BOLT

Submersible Motor

9" REWINDABLE MOTORS

TECHNICAL SPECIFICATIONS:

- 9" Water Lubricated Submersible Motors are rewindable.
- Coupling dimensions: 8" NEMA standard.
- Winding wire: PVC winding
- Degree of protection : IP68.
- Max water temperature : 35°C.
- Starts per hour : 20 time (Max.).
- Allowable voltage variation : +6% - 10%.
- Motor shaft of Stainless steel.
- Stator shell of Stainless steel.
- Max depth immersion : 350 M.
- Mounting : vertical
- Motor Cable length : 3 Meter / 3 Core with separate earth cable.
- Cooling Flow : V:0.2 M/S.
- Coolant : Clear Water.

VERSIONS:

Three Phase : 45 kW To 93 kW / 380-415 Volt /50 Hz

Motor With Other Voltage and frequency ratings are available on specific Demand.

9" REWINDABLE MOTOR

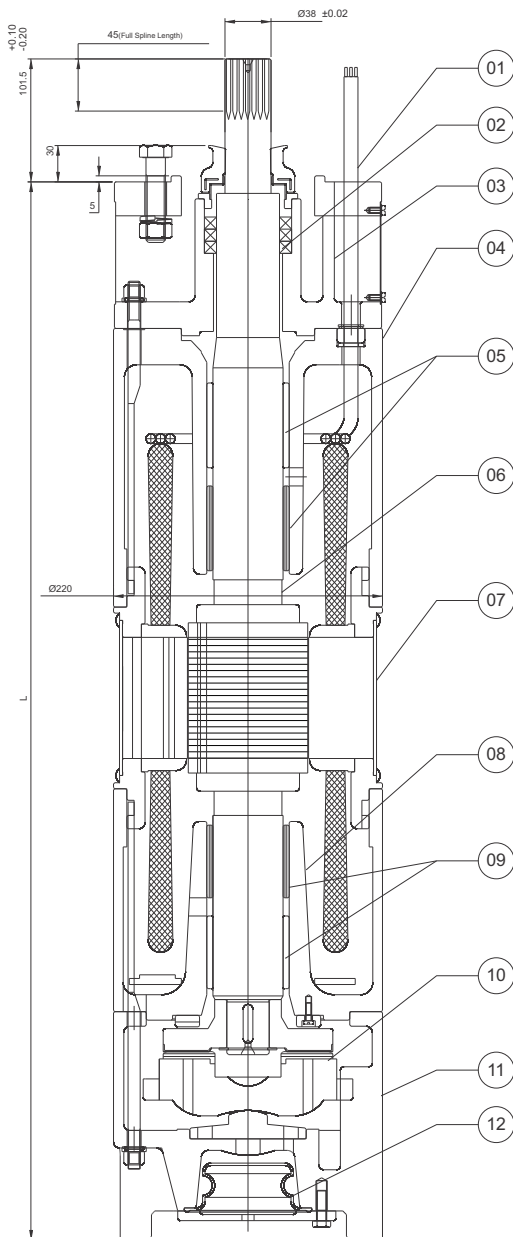
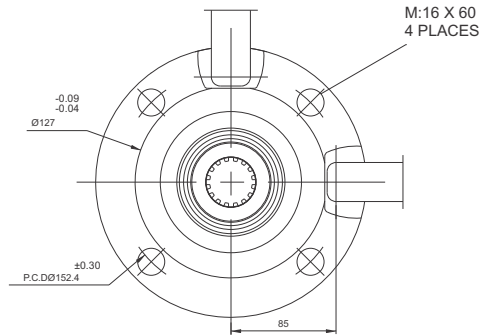

SR NO.	PARTS NAME	MATERIAL
01	CABLE 3 CORE /4 CORE	EPR
02	OIL SEAL	N.B.R
03	ADAPTOR	CAST IRON (FG-200)
04	UPPER HOUSING	CAST IRON (FG-200)
05	BEARING BUSH	LTB-4 (2% Ni.) / M.S-N.B.R
06	ROTOR SHAFT	S.S.431
07	MOTOR SHELL	S.S.304
08	LOWER HOUSING	CAST IRON (FG-200)
09	BEARING BUSH	LTB-4 (2% Ni.) / M.S-N.B.R
10	THRUST BEARING SET	CARBON / S.S.420
11	MOTOR BASE	CAST IRON (FG-200)
12	PRESSURE CUP	H.B.R
13	ALL HARDWARE	S.S.304

P _N		PW L [mm] Cast Iron	MOTOR WEIGHT [kg]	MOTOR WEIGHT (incl.pkg) [kg]
[kW]	[HP]		Cast Iron	Cast Iron
45.0	60.00	1274.0	165.0	183.0
52.0	70.00	1404.0	262.0	342.0
55.0	75.00	1404.0	262.0	342.0
67.0	90.0	1474.0	275.0	355.0
75.0	100.0	1544.0	300.0	360.0
93.0	125.0	1544.0	300.0	360.0

Submersible Motor

Technical Data of 9" Motors / 50 Hz

PN		Thrust Load [N]	UN [V]	nN [min-1]	IN [A]	IA [A]	ι (Eff.) [%] at % load			cos κ (PF) at % load			TN [Nm]	TA [Nm]
[H.P.]	[kW]						50	75	100	50	75	100		
60	45						45000	380	2905	93.1	490	86.0		
		400	2915	90	520	85.5		86.4	85.9	0.75	0.84	0.87	154	241
		415	2920	88	540	84.8		86.3	85.7	0.70	0.80	0.85	154	262
75	55	45000	380	2910	114	624	86.8	87.0	85.6	0.79	0.85	0.89	193	301
			400	2915	110	660	85.9	86.9	86.3	0.73	0.83	0.87	193	341
			415	2920	108	687	84.9	87.1	86.1	0.66	0.79	0.86	193	367
100	75	45000	380	2905	153	891	86.8	87.2	85.8	0.78	0.85	0.88	258	420
			400	2920	148	942	86.2	87.4	86.8	0.75	0.84	0.85	257	471
			415	2915	146	983	85.5	86.8	86.5	0.68	0.78	0.84	257	511
125	93	45000	380	2905	187	1185	87.9	88.5	87.7	0.78	0.84	0.87	305	558
			400	2915	182	1275	87.3	88.4	87.8	0.72	0.82	0.86	304	627
			415	2925	183	1309	86.3	87.7	87.6	0.66	0.77	0.84	304	677

- PN - Rated Output
- F[N] - Axial Thrust Load
- UN - Rated Voltage
- nN - RPM
- IN - Full Load Current
- IA - Starting Current
- ι - Motor Efficiency
- cosκ - Power Factor
- TN - Full Load Torque
- TA - Starting Torque

Exploded Drawing of 9" Motor

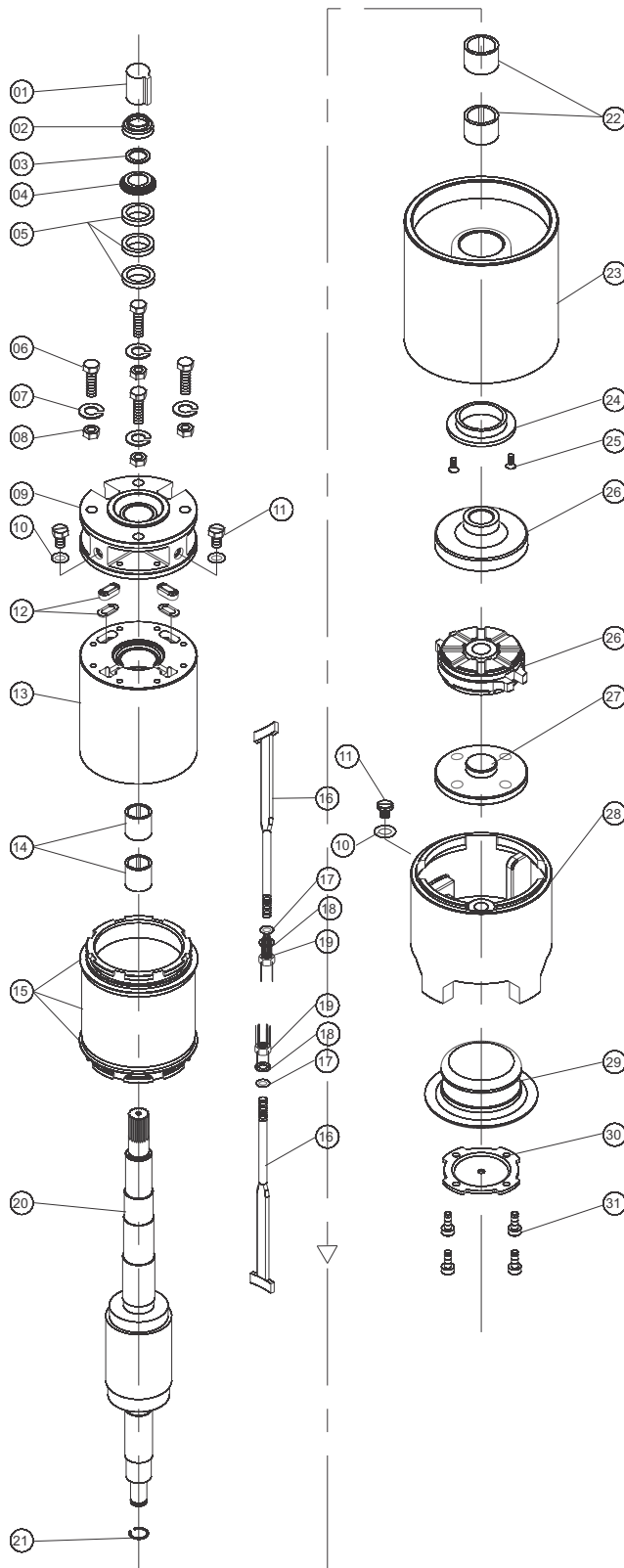

Sr.No.	PARTS NAME
01	ROTOR CAP
02	SAND GUARD
03	TEFLON WASHER
04	UPPER CAP
05	OIL SEAL
06	HEX BOLT
07	SPRING WASHER
08	HEX NUT
09	ADOPTOR
10	DRAIN PLUG 'O' RING
11	DRAIN PLUG
12	GROMMET & WASHER
13	UPPER HOUSING
14	BEARING BUSH
15	STATOR BODY FINISH FLANGE (USE FOR UPPER & LOWER SIDE)
16	T-BOLT(UPPER SIDE) T-BOLT(LOWER SIDE)
17	T-BOLT 'O'RING
18	T-BOLT WASHER
19	NYLOCK NUT
20	ROTOR FINISH
21	CIR CLIP(USE FOR ROTOR)
22	BEARING BUSH
23	LOWER HOUSING
24	C.T BEARING
25	C.S.K SCREW
26	COUNTER BEARING
27	ROCKER PLATE
28	MOTOR BASE
29	PRESSURE CUP
30	MOTOR BASE PLATE
31	HEX BOLT

Submersible Motor

10" REWINDABLE MOTORS

TECHNICAL SPECIFICATIONS:

- 10" Water Lubricated Submersible Motors are rewindable.
- Coupling dimensions: 8" NEMA standard.
- Winding wire: PVC winding
- Degree of protection : IP68.
- Max water temperature : 35°C.
- Starts per hour : 20 time (Max.).
- Allowable voltage variation : +6% - 10%.
- Motor shaft of Stainless steel.
- Stator shell of Stainless steel.
- Max depth immersion : 350 M.
- Mounting : vertical
- Motor Cable length : 3 Meter / 3 Core with separate earth cable.
- Cooling Flow : V:0.2 M/S.
- Coolant : Clear Water.

VERSIONS:

Three Phase : 110 kw to 150 kw / 380-415 Volt /50 Hz

Motor With Other Voltage and frequency ratings are available on specific Demand.

10" REWINDABLE MOTOR

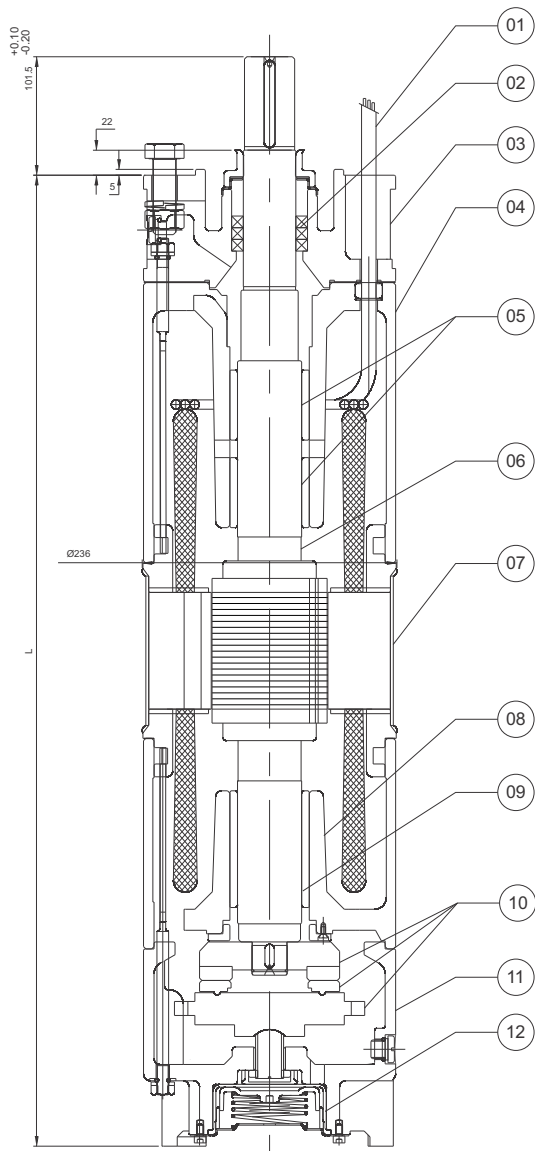
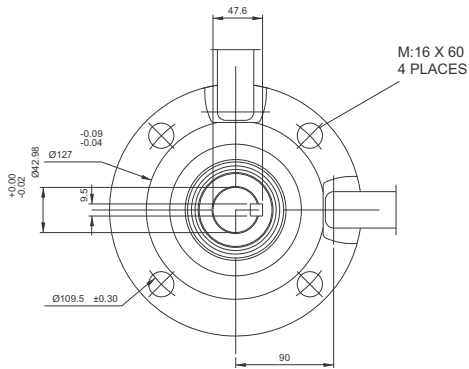

SR NO.	PARTS NAME	MATERIAL
01	CABLE 3 CORE /4 CORE	EPR
02	OIL SEAL	N.B.R
03	ADAPTOR	CAST IRON (FG-200)
04	UPPER HOUSING	CAST IRON (FG-200)
05	BEARING BUSH	LTB-4 2% Ni.
06	ROTOR SHAFT	S.S.420
07	MOTOR SHELL	S.S.202
08	LOWER HOUSING	CAST IRON (FG-200)
09	BEARING BUSH	LTB-4 2% Ni.
10	THRUST BEARING SET	CARBON / S.S.420
11	MOTOR BASE	CAST IRON (FG-200)
12	PRESSURE CUP	H.B.R
13	ALL HARDWARE	S.S.304

P_N		PW L [mm] Cast Iron	MOTOR WEIGHT [kg]	MOTOR WEIGHT (incl.pkg) [kg]
[kW]	[HP]		Cast Iron	Cast Iron
110.0	150.0	1636.0	306.0	366.0
150.0	200.0	1911.0	357.0	427.0

Submersible Motor

Technical Data of 10" Motors / 50 Hz

PN		Thrust Load [N]	UN [V]	nN [min-1]	IN [A]	IA [A]	η(Eff.) [%] at % load			COS φ (PF) At % load			TN [Nm]	TA [Nm]
[H.P.]	[kW]						50	75	100	50	75	100		
150	110	60 000	380	2905	236	1096	85	86	85	0.73	0.82	0.86	360	419
			400	2915	231	1157	85	87	85	0.65	0.77	0.83	359	468
			415	2920	232	1205	83	84	86	0.60	0.71	0.80	359	508
200	150	60 000	380	2910	306	1501	88	88	87	0.80	0.84	0.87	491	569
			400	2915	297	1589	85	87	86	0.75	0.82	0.87	490	636
			415	2930	295	1654	87	88	88	0.70	0.78	0.84	489	690

- PN - Rated Output
- UN - Rated Voltage
- nN - RPM
- IN - Full Load Current
- IA - Starting Current
- η - Motor Efficiency
- cosκ - Power Factor
- TN - Full Load Torque
- TA - Starting Torque
- F[N] - Axial Thrust Load

Exploded Drawing of 10" Motor

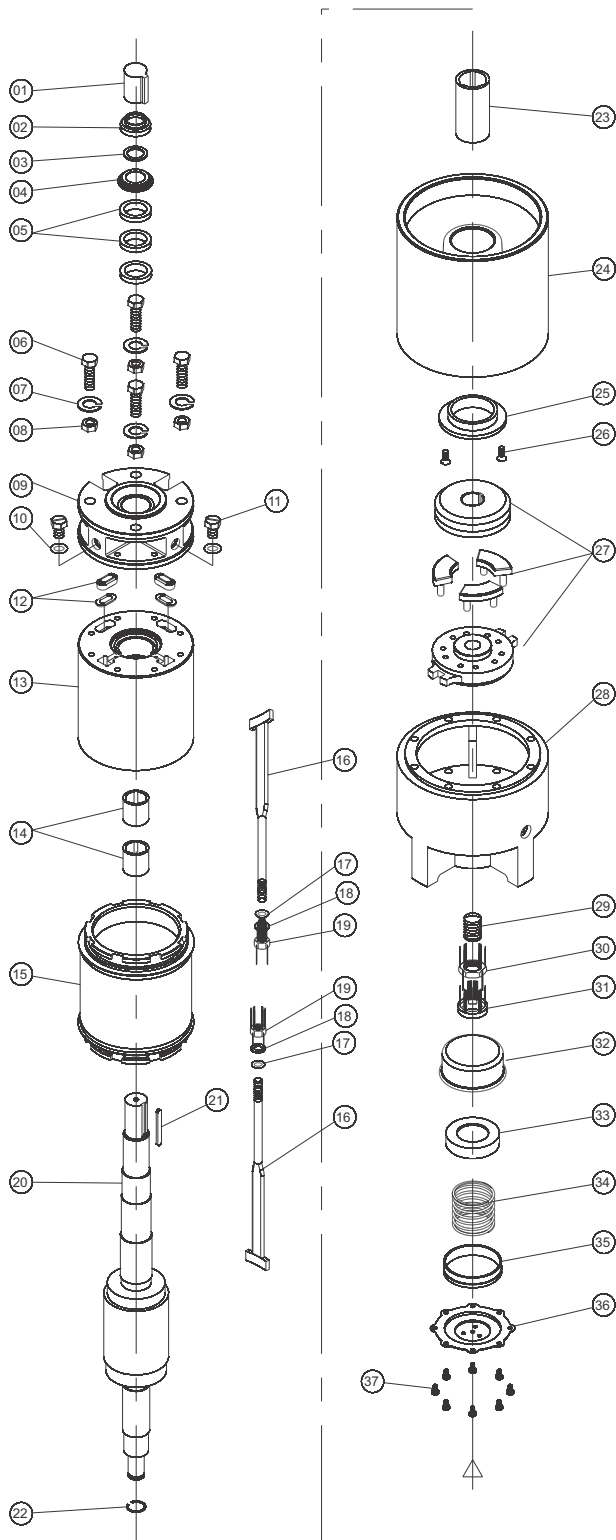

Sr.No.	PARTS NAME
01	ROTOR CAP
02	SAND GUARD
03	TEFLON WASHER
04	UPPER CAP
05	OIL SEAL
06	HEX BOLT
07	SPRING WASHER
08	HEX NUT
09	ADOPTOR
10	DRAIN PLUG 'O' RING
11	DRAIN PLUG
12	GROMMET & WASHER
13	UPPER HOUSING
14	BEARING BUSH
15	STATOR BODY FINISH FLANGE (USE FOR UPPER & LOWER SIDE)
16	T-BOLT(UPPER SIDE) T-BOLT(LOWER SIDE)
17	T-BOLT 'O'RING
18	T-BOLT WASHER
19	NYLOCK NUT
20	ROTOR FINISH
21	KEY (USE FOR COUPLING SIDE)
22	CIR CLIP(USE FOR ROTOR)
23	BEARING BUSH
24	LOWER HOUSING
25	C.T BEARING
26	C.S.K SCREW (USE FOR C.T BEARING)
27	CARBON BEARING SET
28	MOTOR BASE
29	ROCKER
30	ROCKER NUT
31	ROCKER NUT CAP
32	PRESSURE CUP
33	SPRING JACKET-2
34	SPRING
35	SPRING JACKET-1
36	MOTOR BASE PLATE
36	SLOTTES ROUNDHEAD SCREW

الوكيل الوحيد في الجمهورية اليمنية

لشركة فارونا للمضخات الغاطسة



مؤسسة عامر جميدة للتجارة والتوكيلات العامة

العنوان:

الجمهورية اليمنية - صنعاء شارع خولان

تليفون: ٠١٦٢٥٣٣٣ / ٠١٦٠٨٣٣٣ - موبايل ٧٧١١٣٣٣٣٣

البريد الإلكتروني:

Amerjumaidah@hotmail.com

Info@varunapumps-yemen.com



La-Gajjar Machineries Pvt. Ltd.,

Acidwala Estate, Nagarwel Hanuman Road, Amraiwadi, Ahmedabad- 380026, Gujarat, INDIA

Phone No.: +91- 79- 22777485/87/89 | Website: www.varunapumps.com

Email: internationalbusiness?lgmindia.com